

ICANS-VI

INTERNATIONAL COLLABORATION ON ADVANCED NEUTRON SOURCES

June 27 - July 2, 1982

THE IPNS-I CHOPPER SPECTROMETERS

D. L. Price, J. M. Carpenter, C. A. Pelizzari,
S. K. Sinha, I. Bresof and G. E. Ostrowski

Argonne National Laboratory, Argonne, Illinois 60439 U.S.A.

ABSTRACT

We briefly describe the layout and operation of the two chopper experiments at IPNS-I. The recent measurement on solid ^4He by Hilleke et al. provides examples of time-of-flight data from the Low Resolution Chopper Spectrometer.

THE IPNS-I CHOPPER SPECTROMETERS

D. L. Price, J. M. Carpenter, C. A. Pelizzari
S. K. Sinha, I. Bresof and G. E. Ostrowski

Argonne National Laboratory, Argonne, Illinois 60439 U.S.A.

The chopper spectrometers at IPNS-I enable measurements of inelastic scattering with energy transfers in the range 40-800 meV. Detectors placed at many different angles determine the scattering as a function of wave vector Q as well as energy transfer E . As an example, Fig. 1 shows the region of (Q,E) space opened up by the use of 500 meV neutrons compared with the region accessible to 100 meV neutrons, which are towards the upper end of the range available at reactors. The aim of the chopper spectrometers at IPNS-I is to explore the new scientific opportunities in this new (Q,E) region.

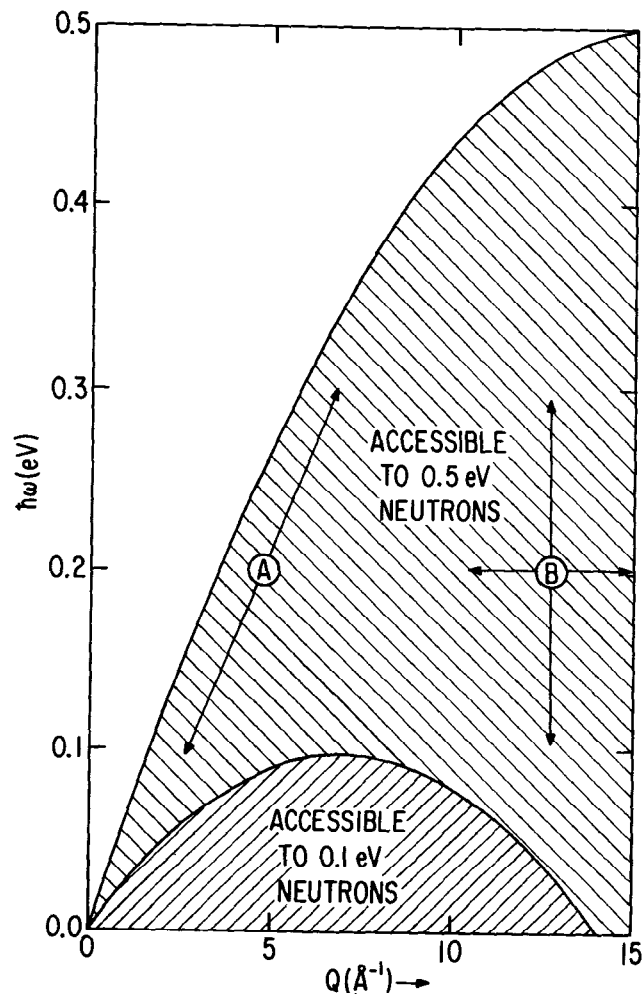

Fig. 1 Region of (Q, E) space opened up by 500 meV neutrons compared with 100 meV ($E = h\omega$).

Fig. 2 shows a schematic of the layout for the two spectrometers now existing at IPNS-I. By increasing the distances d_1 and d_3 the resolution is improved but at the expense of intensity. The two machines, Low-Resolution Medium-Energy Spectrometer (LRMECS) and High-Resolution Medium-Energy Chopper Spectrometer (HRMECS) represent different compromise positions with respect to this trade-off. The dimensions for the two machines are given in the figure.

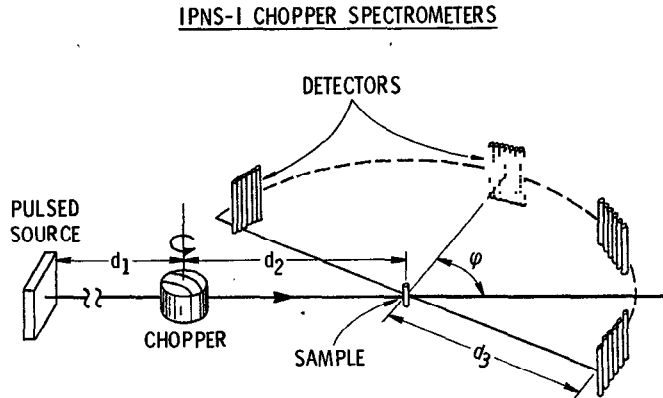

Fig. 2

Schematic of the layout and dimensions of the two chopper spectrometers at IPNS-I.

	d_1	d_2	d_3	$\Delta E/E_0$	ϕ
LRMECS	6.2 m	0.6 m	2.5 m	6-8%	-10° to +120°
HRMECS	12.8 m	1.1 m	4.0 m	3-4%	-20° to +20°

The chopper has a body of beryllium with aluminum end-caps; boron fiber/aluminum composite defines the slits; details are given elsewhere¹.

The system shown in Figure 3 maintains the choppers for these and other

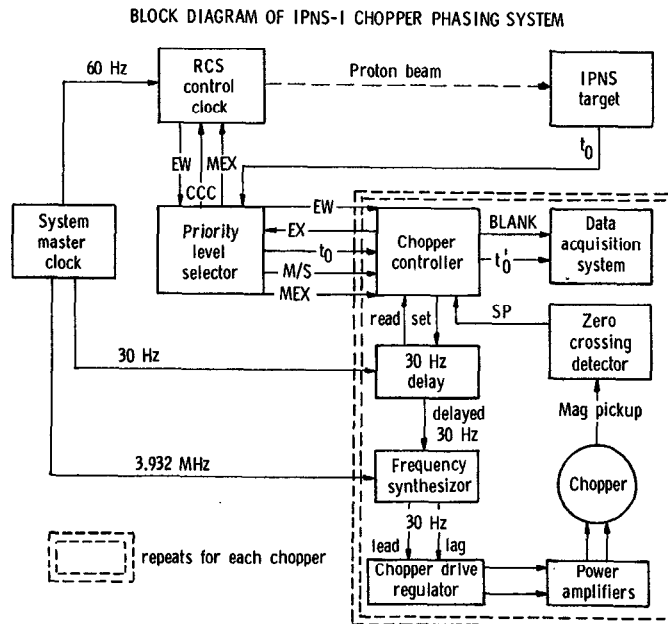

Fig. 3

Summary of the scheme for chopper phasing at IPNS-I.

machines in a fixed phase relation to the accelerator². A key element is the system master clock, based on a crystal oscillator and sending synchronized driving pulses to the Rapid Cycling Synchrotron (RCS) and the choppers. Each chopper circuit (in the dashed-line box in Fig. 3) generates a signal demanding extraction from the accelerator, based on the t_0 signal from the target, the chopper period and a preset delay time. The priority level selector sends the highest priority (relative to a preassigned hierarchy) valid extraction signal to the RCS. The logic of the phasing mechanism is shown in detail in Fig. 4. The system performs excellently with the two choppers running simultaneously.

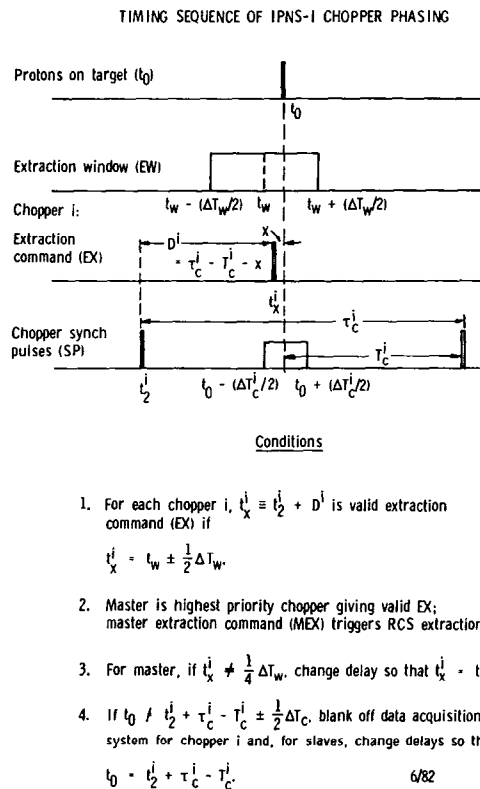

Fig. 4. Timing sequence and logic of the chopper phasing system.

Approximately 100 ^3He proportional counters in each instrument detect scattered neutrons. The signals run to the IPNS-I Data Acquisition System³; the software enables signals from individual detectors to be binned singly or together as a larger group. The data are analyzed on the VAX 11-780 using general purpose programs which have been developed⁴. Fig. 5 gives a summary of the scheme involved.

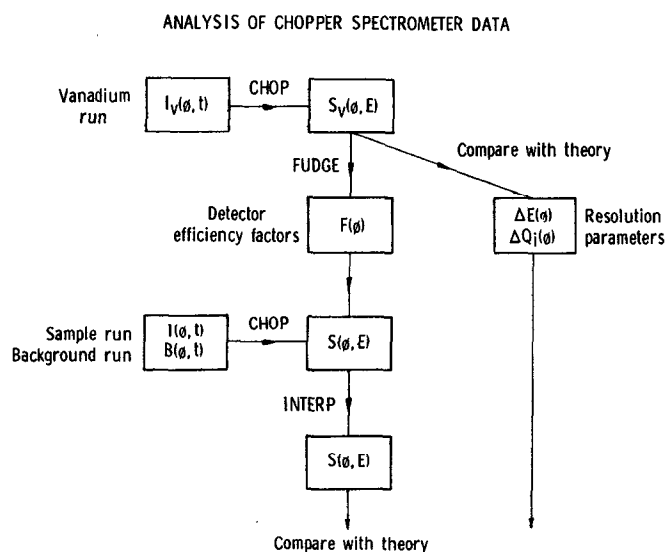

Fig. 5

Summary of the scheme for chopper data analysis.

Since HRMECS has only just become operational, we now limit our discussion to LRMECS. Table I lists the experiments recommended by the Program Committee for the first year of full operation. At the present time all experiments recommended for the first half-year have been run and are in various stages of data analysis. In some cases additional data are needed.

As an example, we show raw time-of-flight data for the solid ^4He experiment⁵. The data were taken with $E_0 = 500$ meV. The object was to determine the ground state momentum distribution in hcp solid ^4He .

Figure 6 shows the scans through (Q, E) space corresponding to a fixed detector as a function of angle. Peaks are expected at the points where the curve for the recoil energy

$$E_R = \frac{\hbar^2 Q^2}{2M}$$

crosses the (Q, E) scans ($M =$ mass of scattering atom).

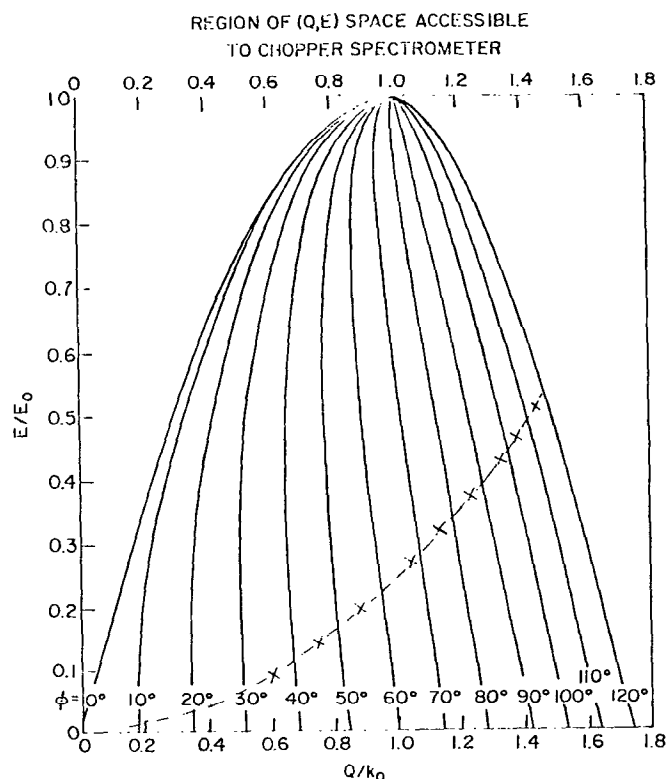

Fig. 6

(Q, E) conditions for the ^4He experiment. The solid curves are the loci through (Q, E) space scanned by detectors at the angles indicated. The dashed curve is the recoil energy for ^4He . The crosses indicate the peak positions in the measurement of Hilleke *et al.* (Ref. 5). $E_0 = 505 \text{ meV}$, $k_0 = 15.6 \text{ \AA}^{-1}$.

The remaining figures show the count rate as a function of time for three angles. The circles represent the scattering with the container full and the lines the empty container scattering normalized by monitor counts to the full container run. Fig. 7 shows the helium peak at a small angle, $\phi = 7.5^\circ$, where the recoil energy is very small and the helium peak is superimposed on the scattering from the container.

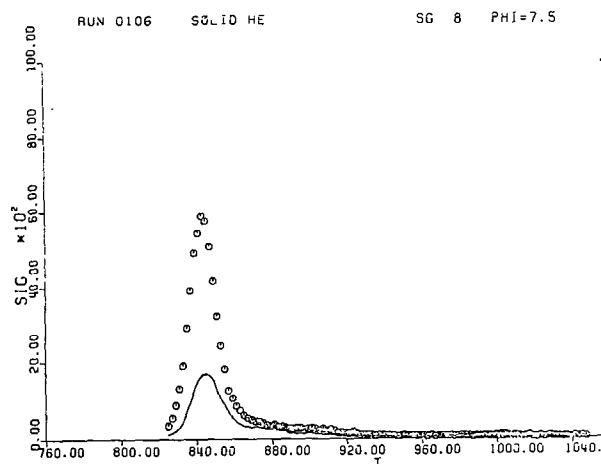

Fig. 7

Curve of scattering from ^4He (open circles) compared with that from the empty container (normalized to the sample run) at room temperature, $\phi = 7.5^\circ$ (Hilleke *et al.*, Ref. 5).

As the angle is increased the helium peak begins to move away from the container scattering ($\phi \sim 57^\circ$, Fig. 8), and at larger angles it becomes well resolved ($\phi \sim 87^\circ$, Fig. 9). The data for the signal run were accumulated in 40 hours with a current of 8 μA of 400 MeV protons. At the present time analysis is underway to provide the scattering function $S(Q,E)$ to compare with theoretical calculations.

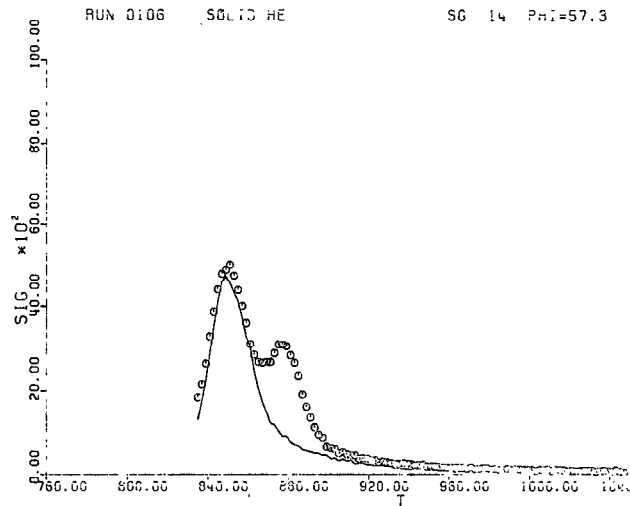

Fig. 8

Curve of scattering from ^4He (open circles) compared with that from the empty container (normalized to the sample run) at room temperature, $\phi = 57.3^\circ$ (Hilleke et al., Ref. 5).

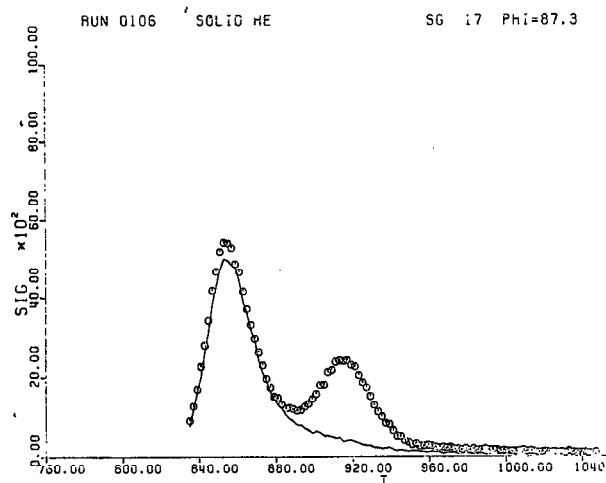

Fig. 9

Curve of scattering from ^4He (open circles) compared with that from the empty container (normalized to the sample run) at room temperature, $\phi = 87.3^\circ$ (Hilleke et al., Ref. 5).

References

1. R. Kleb, C. A. Pelizzari and J. M. Carpenter "Fermi Choppers for Epithermal Neutron Beams", to be published.
2. W. Praeg, D. McGhee and G. Volk "Phase Lock of Rapidly Cycling Synchrotron and Neutron Choppers", IEEE Trans. Nucl. Sci. NS-28, 2171 (1981).
3. R. K. Crawford, R. T. Daly, J. R. Haumann, R. L. Hitterman, C. B. Morgan, G. E. Ostrowski and T. G. Worlton "The Data Acquisition System for the Nuclear Scattering Instruments at IPNS-I", IEEE Trans. Nucl. Sci. NS-28, 3692 (1981).
4. D. L. Price, "IPNS-I Chopper Data Analysis Programs", June 1, 1982 (unpublished).
5. R. O. Hilleke, P. Chaddah, R. O. Simmons, D. L. Price and S. K. Sinha (to be published).

TABLE 1. LIST OF EXPERIMENTS RECOMMENDED BY THE PROGRAM COMMITTEE
FOR THE FIRST YEAR OF LRMECS

LOW-RESOLUTION MEDIUM-ENERGY CHOPPER SPECTROMETER

Accepted Proposals November 1981 - April 1982

6	S. A. Werner G. Shirane	U. of Missouri Brookhaven	High Energy Magnetic Excitations in Pure Chromium	7 days
71	R. O. Hilleke R. O. Simmons P. Chaddah S. K. Sinha	U. of Illinois U. of Illinois Bhabha At. En. Res. Cntr. Argonne	Momentum Density of HCP ^4He	10 days
43	J. M. Carpenter C. A. Pelizzari D. F. R. Mildner	Argonne Argonne U. of Missouri	Mapping the Scattering Law for Vitreous SiO_2	7 days
57	S. M. Shapiro S. K. Sinha	Brookhaven Argonne	Measurement of Spin Dynamics in the Mixed Valence Alloy $\text{Ce}_{1-x}\text{Th}_x$	7 days (with #65)
58	J. S. Lannin L. Pilione R. Magaña S. K. Sinha	Penn State U. Penn State U. Penn State U. Argonne	Time of Flight Study of the Phonon Density of Amorphous Phosphorus	7 days (Backup)
65	R. D. Parks S. Shapiro B. Grier S. K. Sinha	Polytechnic Inst. of New York Brookhaven Brookhaven Argonne	Quasielastic Neutron Scattering Study of $\text{Ce}_{0.9-x}\text{La}_x\text{Th}_{0.1}$	7 days (with #57)

Accepted Proposals May - October 1982

9	S-H. Chen D. L. Price	MIT Argonne	Proton Dynamics in Supercooled Water	2nd Backup
66	S. K. Sinha H. A. Mook B. Goodman	Argonne Oak Ridge U. of Cincinnati	Measurement of the Condensate Fraction of ^4He in Superfluid ^4He and ^3He - ^4He Solutions	10 days
72	S. K. Sinha A. J. Arko D. L. Price R. M. Nicklow	Argonne Argonne Argonne Oak Ridge	Dynamical Response in the Exchange Enhanced Paramagnet UAl_2	10 x 1/2 days with #127
104	J. R. D. Copley W. S. Howells	McMaster Univ. Rutherford Lab.	Atomic Motion in Liquid Lithium and Selected Lithium Alloys	10 days
127	M. Loewenhaupt	Jülich	Magnetic Excitations in Cerium and Uranium Compounds	10 x 1/2 days with #72
136	P. Blanckenhagen	Karlsruhe	Spin Waves in Ordered Ni_3Mn	1st Backup