

Proceedings of International Collaboration on Advanced Neutron Sources (ICANS-VII), 1983 September 13-16
Atomic Energy of Canada Limited, Report AECL-8488

TRIUMF THERMAL NEUTRON FACILITY

I.M. Thorson, J.J. Burgerjon, R.E. Blaby and T.A. Hodges
TRIUMF
4004 Wesbrook Mall
Vancouver, B.C. Canada
V6T 2A3

Introduction

The TRIUMF Thermal Neutron Facility (TNF) has been described previously^{1,2} as it was originally installed for operation in 1978. In the January/March 1983 shutdown of the TRIUMF facility the moderator assembly and target were replaced to increase the beam current dissipation capability of the facility in anticipation of increased currents from the 500 MeV isochronous cyclotron. This report will outline these modifications^{3,4,5} and others aimed at increasing the overall operating reliability of the TNF. Some preliminary commissioning test results of the molten target temperature distribution are also reported.

2. Moderator/Target Assembly Modifications

The most significant change in the moderator tank assembly is shown in Fig. 1; in the previous assembly the 15 cm diameter, 25 cm long stainless-steel target container sat in an open cavity at the bottom of the 46 cm diameter water moderator/coolant tank. The heat developed in the target by the residual proton beam was dissipated at the outside of the container by nucleate pool boiling of the water after transfer to the target can wall by convection of the molten lead. The pool-boiling mechanism limited the power dissipation capability of the target to approximately 50 kw based on a conservative estimate of 125 w cm⁻² heat flux limit. To raise this limit the target design was changed to a forced flow regime by enclosing the stainless-steel target can in a secondary aluminum container with pumped H₂O cooling flow over both the front face of the target - as with the original design - and the other target surfaces. The coolant exhausts into the top moderator/coolant tank and the heat is dissipated in a local external heat exchanger, as before. The new target design is estimated to be capable of dissipating 125 kw of heat. Because only about 75% of the proton beam power appears as heat in the target and the upstream meson production targets remove at least 25% of the initial beam the new target design is expected to satisfy TRIUMF's operational beam dump requirements for accelerated beams in excess of 200 kw.

The moderator/coolant assembly was replaced with one that accommodates the new, larger target assembly. The new design, like the old, has a D₂O moderator chamber below the centre plane of the target. Because no use has been made of the neutron beam tubes viewing the lower through-tube section of the D₂O moderator compartment - and none are currently contemplated - the through-tube port was eliminated to reduce the leakage from the D₂O moderator and thereby improve the flux to the existing beam tube and irradiation facilities. The

other substantial change to the moderator/coolant tank assembly was the elimination of the vertical access port to the front of the target, originally intended to accommodate a proton irradiation facility; such facilities have now been installed at a site 75 cm upstream and no further developments are envisaged.

The change to a forced-flow cooling regime for the target did introduce a complication in the cooling circuit design. The loss of pump power during high current operations leaves an inventory of heat in the target that would boil away all of the water in the target coolant channels. To avoid the uncontrolled thermal cycling that could result from the repeated voiding and reflooding (through the coolant outlet port) of the target coolant channel a standby inventory of water was installed at a height to have a pressure head comparable to the operating pump pressure. The inventory is sufficient to supply full target flow for 1-2 minutes following loss of pumping power and the

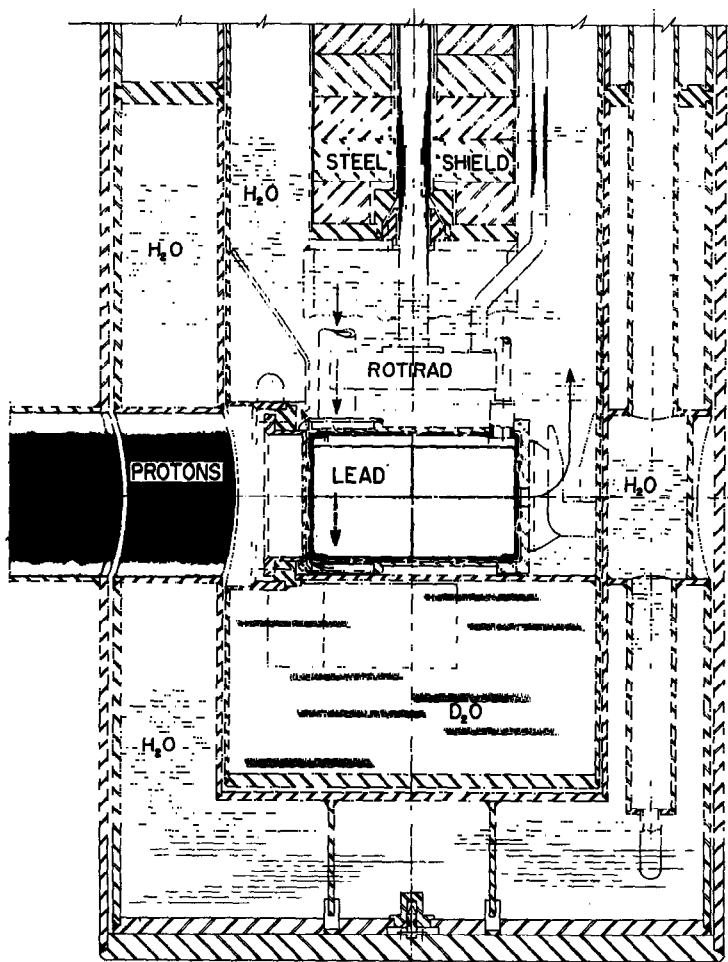

Figure 1. TRIUMF MKII TNF moderator/coolant/target assembly

resulting beam trip.

The first target installed in the new assembly has been extensively instrumented with thermocouples to measure the temperature distribution in the lead as a function of beam power and for various operating conditions. Fig. 2 shows the positions of the 24 thermocouples held by thin stainless-steel baffle plates at five planes of various depths from the front face of the container.

Note that the void space at the top of the target above the lead target core is evacuated and it's pressure monitored to give an early warning of target containment failure, as in the previous design. With the exception of some minor operating problems, since rectified, with the mechanical refrigeration system used to cool the cold-traps needed to remove the volatile activities evolved from the molten lead, this monitoring system has worked well and gives us considerable confidence in the continuing integrity of the target containment system.

The design of the AISI347 stainless-steel target container was based on the ASME pressure vessel code taking into account effects of fatigue due to thermal stress and cycling, radiation and corrosion. The 347 stainless steel was chosen over the type 316 previously

used on the basis of slightly better strength and thermal conductivity characteristics at the operating temperatures expected. The wall thicknesses produced by this design are reduced from the previous design to minimize the bulk lead temperature at the higher heat fluxes intended to dissipate the increased power. The least conservative design indicator was that of fatigue life time of the container wall which was estimated to be in the range of 5000 cycles; the thermal cycling rate has not been a closely established parameter of the system. We are implementing a thermal cycle monitoring system to measure not only the number but also the amplitude of the temperature variations actually experienced by the critical part of the target container.⁶ The thermal stresses in the container, the dominant stress component, are estimated to peak at the onset of melting at the can wall and do not change significantly at higher power levels.

3. Commissioning Test Results

The temperatures shown in Fig. 2 were measured in commissioning tests during operations at 135 A transmitted from the cyclotron down beamline I without significant loss following removal of the meson production targets. Because of stability problems with the proton beam at these power levels there is a rather high noise level on these measurements and some of the apparent anomalies are probably not significant. The general level and rough distribution is reproducible however.

The temperatures in the molten sections of the lead are only weakly dependent on the power level and do not change significantly between 85 and 135 μ A incident beam current. Another interesting feature, from Fig. 2, is that only small sections, if any, of the stainless-steel container walls are in contact with molten lead.

Fig. 3 shows the time dependence of the lead temperatures measured by selected thermocouples during a pump failure test. The principal operating parameter to be determined by these tests was the throttling required in the auxiliary cooling line from the inventory storage tank. Because of the limited inventory the flow rate must be matched roughly to the overall heat dissipation time constant for the target to avoid coolant channel boiling. Note that the length of the temperature plateau at the lead melting point is dependent on the depth of the measuring point from the container wall, as expected.

We intend to repeat these measurements at incident beam power levels up to 150 kw as the accelerator capabilities allow.

1. G.J. Russell, Proceedings of ICANS III Conference on Target Stations and Accelerator Technology, Los Alamos Scientific Laboratory March 19-22, 1979; pp.31.
2. A.S. Arrott et al, "The TRIUMF Thermal Neutron Facility as Planned for Operation in 1978" TRIUMF Report TRI-77-1 (1977).

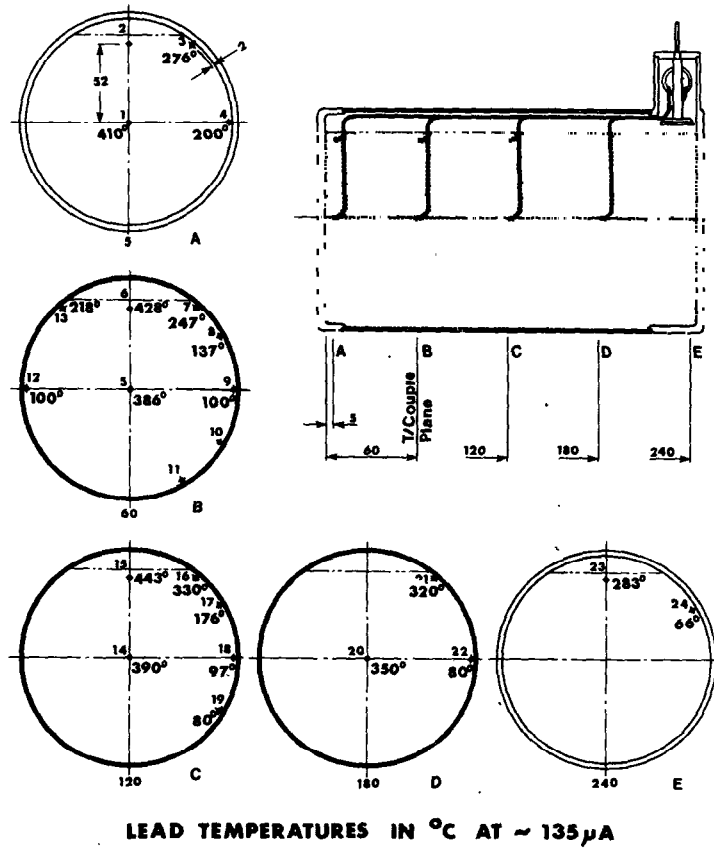

Figure 2. Thermocouple-Temperature Distribution in TNF MKII Target.

3. T.A. Hodges, "TNF Lead Target - Thermal Analysis and Upgrading Feasibility" TRIUMF Design Note VPN-81-2 (1981).

5. R.E. Blaby, et al, "TNF Cooling System" TRIUMF Design Note TRI-DN-86-6 (1982).

4. J.J. Burgerjon, "Upgrading of the TNF Target," TRIUMF Design Note TRI-DN-80-10 (1980).

6. T.A. Hodges, "On-Line Measurement of Thermal Fatigue in the TNF Target", TRIUMF Design Note VPN-83-3 (1983).

Mk II TNF Pb TARGET TEMPERATURES

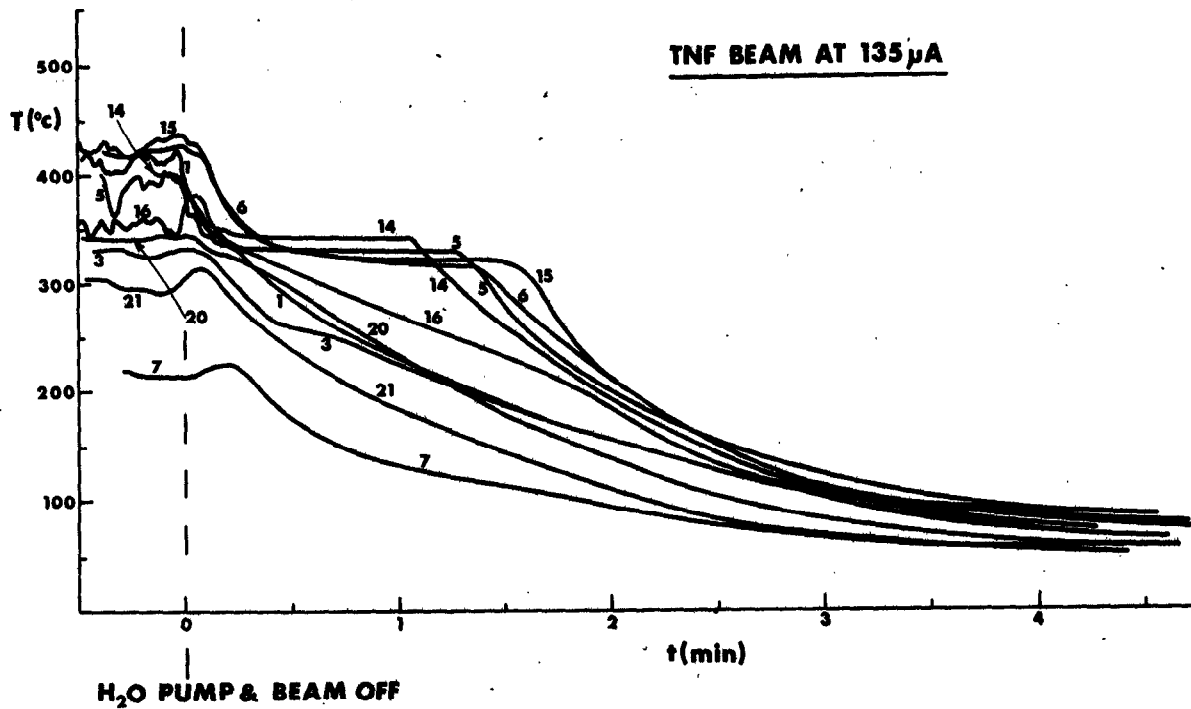

Figure 3. Temperature Decay Curves in MKII TNF Target