

Proceedings of International Collaboration on Advanced Neutron Sources (ICANS-VII), 1983 September 13-16  
Atomic Energy of Canada Limited, Report AECL-8488

BEAM LOADING AND BEAM INSTABILITIES IN HIGH CURRENT ACCELERATORS

K.C.D. Chan and J. McKeown

Atomic Energy of Canada Limited  
Chalk River Nuclear Laboratories  
Chalk River, Ontario, Canada K0J 1J0

Summary

Accelerators with intense beams are important components of spallation neutron sources. This paper summarizes past experiments and present studies on beam induced effects in accelerators with intense beams carried out at Chalk River on the Electron Test Accelerator (ETA).

Introduction

Beam loading and possible beam instabilities from beam induced effects are important in accelerators proposed for spallation neutron sources. At Chalk River, electrons have been used to study the behaviour of intense beams in coupled cavity linac systems<sup>1,2</sup>. Experiments on beam loading with a cw beam up to 20 mA have examined how changes in load impedance of an accelerator structure resulting from changes in beam current can be controlled. These experiments have measured the changes in coupling, quality factor and shunt impedance at different beam loading factors, providing information for optimal design of high current linacs. At the same time, the beam induced TM<sub>110</sub> deflection mode was used successfully to detect the position of the beam centroid<sup>3,4</sup>.

The means for a systematic study of beam loading and beam stability have been gradually acquired over the past seven years. Recently, a pulsed electron gun<sup>5</sup> with 22 nC/pulse has been manufactured so that a study of beam excitations of higher order modes can be undertaken at a beam intensity typical of recently proposed accelerators<sup>6</sup>. Such modes have serious implications for beam stability in high current accelerators. The experimental program has been complemented by theoretical work using the computer codes SUPERFISH<sup>7</sup>, URMEL<sup>8</sup>, RCI<sup>9</sup> and TBCI<sup>10</sup>. These codes have been used to assist with the design of new structures and predict the consequences of interactions between the beam and the structure.

This paper summarizes past work done at Chalk River on the beam cavity interaction and reports on the ongoing physics program. This includes the preparation for injection of pulses from the pulsed electron gun into the graded-β section of ETA, with the aim of demonstrating the space charge effect at high current level, and the physics design for the HERA proton ring linac structure, demonstrating the use of the design codes in calculating beam induced effects.

Underlying Physics

When a beam bunch passes through a cavity, e.g., an accelerating cell in an accelerator structure, transient cavity electromagnetic fields are induced in the cavity volume. Figure 1 depicts a time sequence of a beam bunch passing through a pair of accelerating cavities. The amount of energy U deposited in the cavity is equal to the square of the charge q in the bunch multiplied by a proportional constant k which is a function of cavity geometry and material only. The excitation of the cavity can further be expanded into eigenmode excitations. The excitation of an eigenmode is governed by the Condon<sup>11</sup> formula:

$$\frac{d^2 p_m}{dt^2} + \frac{\omega_m}{Q_m} \frac{dp_m}{dt} + \omega_m^2 p_m = \frac{\omega_m}{2U_m} \int \vec{J} \cdot \vec{E}_m d^3r$$

where  $p_m$  = eigenmode expansion coefficient

$\omega_m$  = mode angular frequency

$E_m$  = mode electric field

$J$  = beam current density

$Q_m$  = mode quality factor

$U_m$  = mode stored energy =  $1/2 \epsilon_0 \int \vec{E}_m \cdot \vec{E}_m d^3r$

This has the form of the equation for a forced harmonic oscillator. In the case of a cw beam, if the bunch frequency is close to the frequency of an eigenmode or its harmonics, the resonant excitation condition will drive the excited mode to an amplitude significantly in excess of its transient value.

A beam particle experiences the induced fields from all the previous particles in addition to the externally applied electromagnetic fields. In recently proposed accelerators, because of their high current, the effects of these induced fields are very significant. They can affect the beam emittance and rf controls in various ways besides being a source of energy loss which must be compensated. The longitudinal electric fields induced by charge at the head of a bunch tend to slow down the particles at the tail and give rise to a variation in particle energy within the bunch. The resonantly induced fundamental mode field gives rise to a beam dependent component of rf acceleration which the control loops have to compensate by adjusting the drive to the external rf source. The dipole mode transverse magnetic fields will deflect beam away from the axis. The quadrupole mode fields give rise to beam dependent focusing and defocusing forces. Therefore, in order to obtain a stable beam system under heavy beam loading and avoid beam induced instabilities, beam induced effects must be studied in detail.

Past Experiments with Intense Beams

The beam loading experiments have been described in detail in references 1 and 2. The graded-β structure of the Electron Test Accelerator was used to deliver a cw electron beam up to 20 mA at 1.4 MeV, and beam loading experiments were carried out in a β=1 structure. The latter is a side-coupled structure consisting of 18 accelerating cells. Both structures operate in the π/2 coupled mode of the TM<sub>010</sub>-like passband at a frequency of 805 MHz. Beam loading of 80% was achieved in the β=1 structure at an average accelerating gradient up to 0.2 MV/m.

Under high beam loading conditions and at different field gradients, the progressive shift from over to undercoupling between the accelerating structure and the rf source was observed. No significant change of the shunt impedance was found for accelerating gradients of 0.1 to 0.8 MV/m and beam loading factors of 80 to 10%, respectively. The relationship between the admittance phase angle and the beam phase angle was found to be a strong function of beam loading. Also the beam induced power at the operating mode was observed to vary as the square of the current. These experiments provide necessary design information for

systems at the more economically desirable gradients of 1 MeV/m and beyond.

The beam position monitors were described in references 3 and 4. The beam induced  $TM_{110}$  mode oscillation in a cavity, often a major cause of beam instability because of the mode magnetic field normal to the beam, was used to advantage for detecting beam displacement. The beam position was measured by measuring the beam induced power that is proportional to the square of the product of the beam current and beam displacement. The position information obtained correlated well with that derived from self-powered detectors<sup>12</sup> and had a position sensitivity of  $0.14 \text{ mW}\cdot\text{mm}^{-1/2}\cdot\text{mA}^{-1/2}$ . The position information was subsequently used in a feedback loop to control the drive current in a steering magnet upstream, thereby maintaining the beam on axis. At 1 mA, the beam was maintained on axis to better than a fraction of a millimeter.

#### Present Work with Intense Beam

##### Pulsed Electron Gun Injection

Fabrication details and properties of the pulsed gun have been described in reference 5. The gun produces electron pulses at 5 kHz with  $1.4 \times 10^{11}$  electrons (22 nC) per pulse and a pulse half width of 3 ns. This section describes the calculations of the injection of these high intensity pulses into ETA, including space-charge effects. Similar calculations have been reported recently for the free electron laser at LANL<sup>13</sup> and for the Stanford Linear Collider<sup>14</sup>.

Some beam properties in the injection line are shown in Fig. 2. A series of four coils (K1-K4) are required to produce an approximately uniform longitudinal magnetic field of 15 mT to compensate for the transverse space charge force along the bunching distance between the buncher and M4 accelerator. A gap lens (L1) is used to tailor the beam for injection to this length and another gap lens (L2) for going into M4. The transverse beam envelope is also shown. With no buncher power, the scalloping of the beam envelope is limited to 0.7 mm around a beam radius of 9 mm. With the buncher turned on, the radial buncher field produces a time dependent deflecting force on the off-axis particles and increases the effective transverse emittance of the beam. This effect increases with larger beam radius. At a beam radius of 9 mm, the estimated increase in divergence of 9 mrad will increase the effective beam emittance by as much as  $10.31 \pi\cdot\text{cm}\cdot\text{mrad}$  compared to the gun intrinsic emittance of  $5.66 \pi\cdot\text{cm}\cdot\text{mrad}$ . This effect is included in the calculations and results are shown as the dashed curves in Fig. 2.

Results of longitudinal bunching calculations are shown in Fig. 3. In the calculations, the electron pulse is represented by disks of charge distributed along the axis. Each disk is further divided radially into two rings. The radii of these rings are assumed to be constant. The forces taken into consideration are the buncher field and Coulomb forces between the rings and their image charges on the beam pipe.

With a buncher peak voltage of 9.79 kV, the beam continues to bunch up to 60 cm from the buncher with 60% of the electrons falling into a phase interval of  $100^\circ$ . After 60 cm, the density of electrons at the center of the bunch becomes very large producing a debunching effect as demonstrated by the bunch widening at 80 and 100 cm. Results also show that the

space charge effects are milder for the outer rings because they receive greater compensating forces from the image charges on the beam pipe. Therefore, at this buncher voltage and a current level of 5.2 A, the bunching efficiency is limited by the longitudinal space charge effect.

##### HERA Proton Ring Structure Design

HERA<sup>6</sup> is a proton-electron collider designed for 820 GeV protons and 30 GeV electrons or positrons at the DESY laboratory in Hamburg. The proton beam contains high density bunches with  $3 \times 10^{11}$  protons/bunch. At an accelerating gradient of 0.868 MV/m and an average beam current of 0.53 A, the beam loading is as high as 94%. Calculations show that the induced field in the accelerating mode is 0.8 MV/m which is of similar magnitude to the field from external rf sources.

Figure 4 shows a proposed<sup>15</sup> cavity geometry (208.5 MHz) derived by scaling the dimensions of an optimized PETRA cavity (500 MHz). The scaled geometry was further optimized with SUPERFISH<sup>7</sup> calculations by varying the gap length to give maximum  $ZT^2$  of 27.74  $\text{M}\Omega/\text{m}$  at a ratio of gap length to cavity length (g/L) of 0.56.

The beam induced fields in the cavity were calculated with the codes SUPERFISH<sup>7</sup>, URMEL<sup>8</sup>, RCI<sup>9</sup> and TRCI<sup>10</sup> (Fig. 5). For axially symmetric modes, the energy loss to higher order modes ( $k_{hm}$ ) is 1.13 times the energy loss to the fundamental mode and increases with larger gap length. The total energy loss to all axially symmetric modes ( $k_T$ ) is  $0.293 \text{ V}\cdot\text{pC}^{-1}\cdot\text{m}^{-1}$  and increases by 10% due to the increase of  $k_{hm}$  when g/L increases from 0.5 to 0.7. The energy loss parameter  $k_{110}$  to the first dipole mode ( $TM_{110}$ -like) is  $0.0053 \text{ V}\cdot\text{pC}^{-1}\cdot\text{m}^{-1}$  and decreases by 70% when g/L increases from 0.5 to 0.7. The opposite trends of  $k_{hm}$  and  $k_{110}$  indicate that there is an optimum g/L value for loss of energy to higher order modes. The optimum value can be obtained by using the above information with the shapes of wake functions calculated from RCI and TRCI in beam dynamics tracking programs like WAKETRAC<sup>16</sup>, which has been successful in predicting the threshold beam current, and energy and phase spread in PETRA and LEP rings<sup>17</sup>. Beam instabilities for a wake field accelerator have been similarly studied<sup>16</sup>. It is apparent from these calculations that the conventional method of accelerator structure optimization by changing the shape to improve the shunt efficiency is inappropriate for high current accelerators. Indeed at high beam loading the overall efficiency must be optimized by considering fields excited by an external source and those by the beam.

##### Conclusion

Understanding of the beam cavity interaction is increasing. Effects of beam loading in a bi-periodic coupled structure were observed and beam induced  $TM_{110}$  mode fields in cavities were used successfully to measure beam displacement. The injection of the beam pulse from a new high intensity pulsed gun was studied. At a current of 5.2 A, the bunching efficiency was limited by the longitudinal space charge forces. The time dependence of radial buncher fields was found to introduce significant beam emittance growth. Design codes were used to obtain information on beam induced fields in a proposed HERA proton ring accelerating cavity. This information can be used for cavity design and beam stability studies with beam dynamic tracking computer codes.

References

1. G.E. McMichael, J. McKeown and J.S. Fraser, "Beam Loading Experiments with a Side Coupled Structure", Proc. Lin. Acc. Conf., BNL-51134, 180 (1979).
2. J. McKeown, J.S. Fraser and G.E. McMichael, "Field Control in a Standing Wave Structure at High Average Beam Power", Proc. Proton Linear Acc. Conf., Atomic Energy of Canada Limited, Report AECL-5677, 291 (1976).
3. J. McKeown, "Beam Position Monitor Using a Single Cavity", IEEE Trans. Nucl. Sci., NS-26 (3), 3423 (1979).
4. K.C.D. Chan, R.T.F. Bird, M.F. Coulas, J. McKeown and Y.M. Shin, "Experiments with Beam Position Sensors", IEEE Trans. Nucl. Sci., NS-28 (3), 2328 (1981).
5. K.C.D. Chan, R.T.F. Bird and J. McKeown, "The Construction of a Pulsed Electron Gun", Atomic Energy of Canada Limited, Report CRNL-2448 (1983).
6. ECFA Study on HERA, DESY HERA 80/01 (1980).
7. K. Halbach and R.F. Holsinger, "SUPERFISH, A Computer Program for Evaluation of RF Cavities with Cylindrical Symmetry", Particle Accelerators 7, 213 (1976).
8. T. Weiland, "URMEL User Guide", DESY M82-24 (1982).
9. T. Weiland, "BCI - A Computer Program for Transient Electromagnetic Fields of Bunched Beams in Accelerators", CERN/ISR-TH/80-45 (1980).
10. T. Weiland, "Transverse Beam Cavity Interaction, Part 1: Short Range Forces", DESY 82-015 (1982).
11. E.U. Condon, "Forced Oscillations in Cavity Resonators", J. Appl. Phys. 12, 129 (1941).
12. R.B. Shields, "Gamma-Radiation-Induced Current Between Insulated Dissimilar Electrodes", Atomic Energy of Canada Limited, Report AECL-3564 (1970).
13. J. Fraser, "Subharmonic Triple Buncher for a High Efficiency Free Electron Laser", IEEE Trans. Nucl. Sci., NS-30 (4), 3115 (1983).
14. M.R. James and R.H. Miller, "A High Current Injector for the Proposed SLAC Linear Collider", IEEE Trans. Nucl. Sci., NS-28 (3), 3461 (1981).
15. "Proposal, Canadian Participation in the HERA Electron-Proton Colliding Beam Facility at DESY", The Institute of Particle Physics, Canada, 1983.
16. T. Weiland and F. Willeke, "Particle Tracing with Collective Effects in Wake Field Accelerators", to be published, presented at the 1983 High Energy Accelerator Conference.
17. T. Weiland, "On the Quantitative Prediction of Bunch Lengthening in High Energy Electron Storage Rings", DESY 81-088 (1981).

CAVITY EXCITATION BY CHARGED BUNCH  
WAKE ELECTRIC FIELD

ON-AXIS  
COUPLED CAVITIES

( $f/2 = 2.415$  GHz)

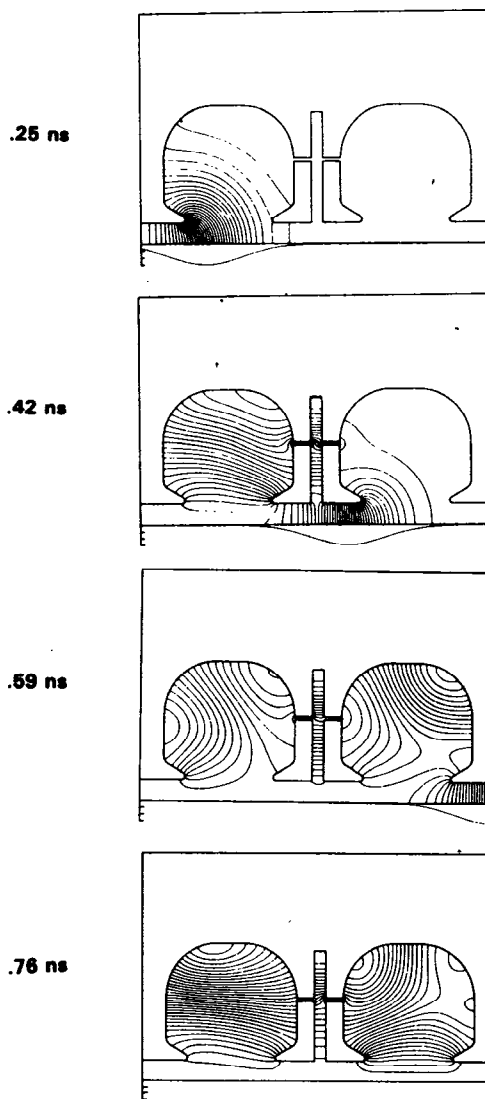

Fig. 1. A time sequence of a beam bunch passing through a pair of accelerating cavities. Induced electric fields are shown as calculated using the computer code BCI. Time zero is when the leading edge of the bunch enters the first cavity.

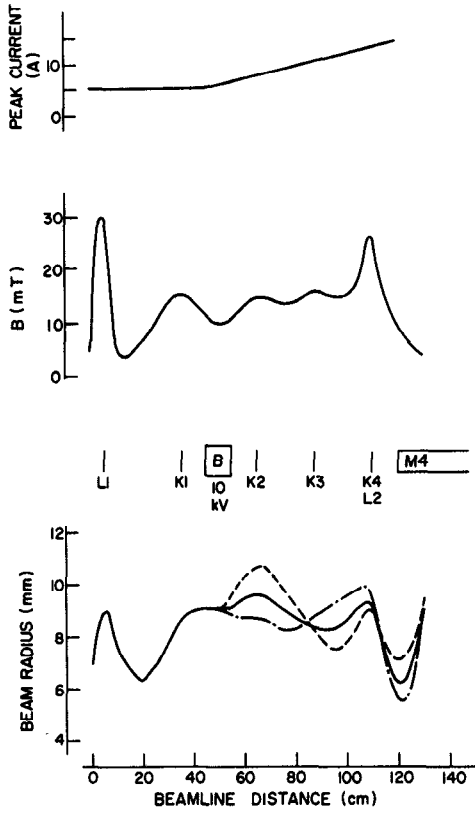

Fig. 2. Transverse beam envelope calculation. L1, L2 = gap lenses; K1, K2, K3, K4 = coils; M4 = accelerator, B = rf buncher. The solid curve is beam radius with buncher off and the dashed curves are with buncher on.

OPTIMIZED HERA PROTON LINAC CAVITY  
208.5 MHz  
(DIMENSIONS IN cm)

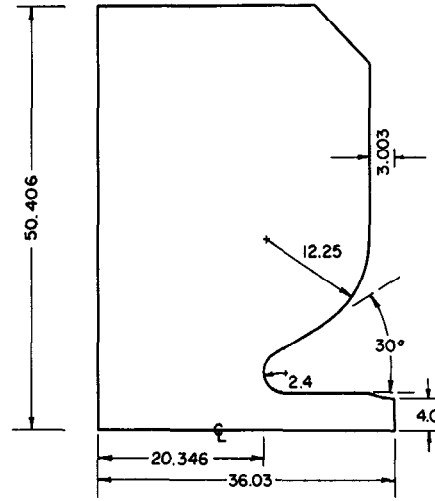

Fig. 4. A proposed cavity shape for the HERA proton ring linac. A half cell is shown with the left boundary at the middle of the cell.

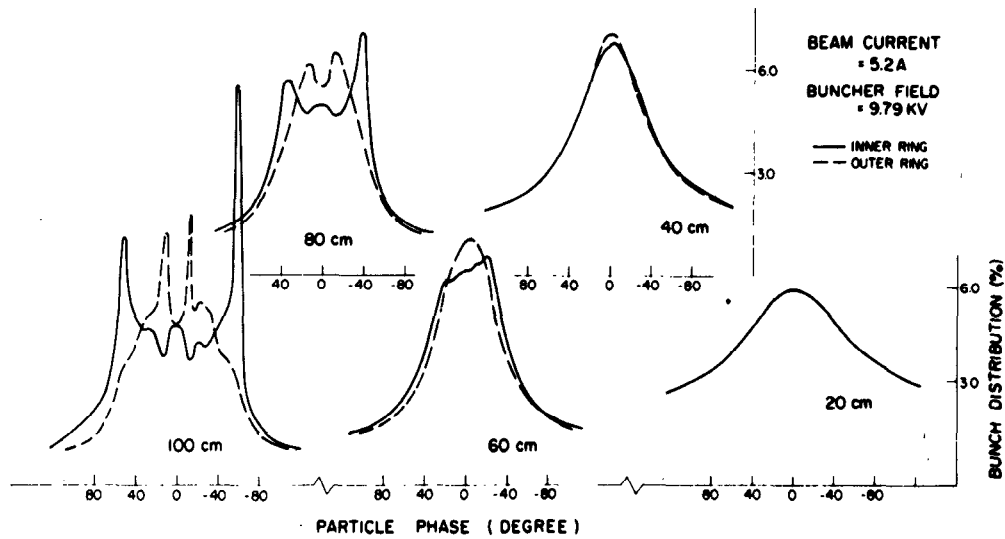

Fig. 3. Calculated longitudinal bunch shape with bunching distance for a current of 5.2 A.

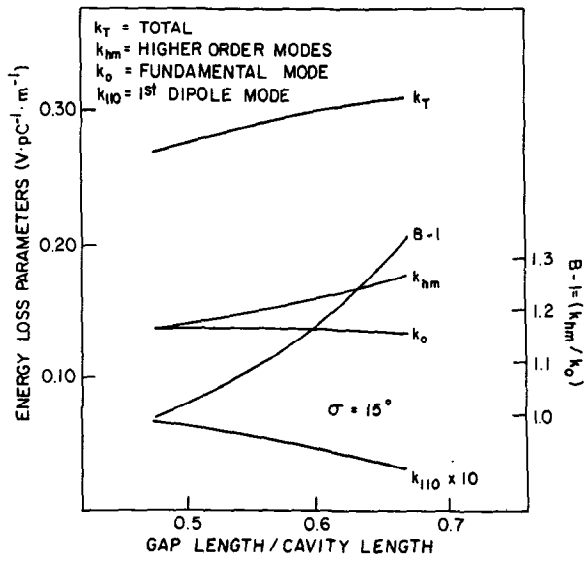

Fig. 5. The energy loss parameters.  $k_{hm}$  and  $k_0$  are for cylindrical symmetric modes. The calculation was done for a gaussian beam hunch with  $\sigma = 15^\circ$ .  $B-1$  is defined as  $k_{hm}/k_0$  and is a measure of the amount of energy going to higher order modes.