

## ICANS-XV

15th Meeting of the International Collaboration on Advanced Neutron Sources

November 6-9, 2000

Tsukuba, Japan

## 12.4

## Single Crystal Spectrometer FOX at KENS

M.Takahashi

Institute of Materials Science, University of Tsukuba, Tsukuba 305-8573, Japan

E-mail:takahasi@bukko.bk.tsukuba.ac.jp

## Abstract

Single crystal spectrometer FOX installed at H1 thermal neutron line on KENS has been renewed recently for the measurement of very weak scattering. We have installed a multidetector system of 36 linearly placed  $^3\text{He}$  detectors with collimators instead of former four-circle diffractometer and scintillator detectors. Though the system is quite simple, a large two-dimensional reciprocal space is observed effectively with high  $S/N$  rate on new FOX.

## 1.Introduction

FOX spectrometer was initially a four-circle single crystal diffractometer with 128 scintillator detectors which was constructed mainly for structural analysis. However, four-circle diffractometer limits the observable reciprocal space and is not suitable for the measurement with white neutrons, where combining with a multidetector system, the observation of a large reciprocal space is possible. Furthermore, the scintillator detectors arise quite high noise due to  $\gamma$ -ray scattering. In recent few years, we have renewed the spectrometer with the purpose of measuring low intensity scattering such as diffuse scattering or superlattice peaks. The spectrometer is intended as a test instrument to design a feature single crystal diffractometer with much stronger source. Recent studies on FOX have proved a good performance and importance of this kind of spectrometer.

## 2.Outline of new FOX

In renewing the FOX, four-circle diffractometer was removed to measure larger reciprocal space, and detector bank with linearly aligned 36  $^3\text{He}$  detectors and collimators were installed instead of scintillator detectors for higher  $S/N$  rate.

Fig.1 Overview of the FOX spectrometer

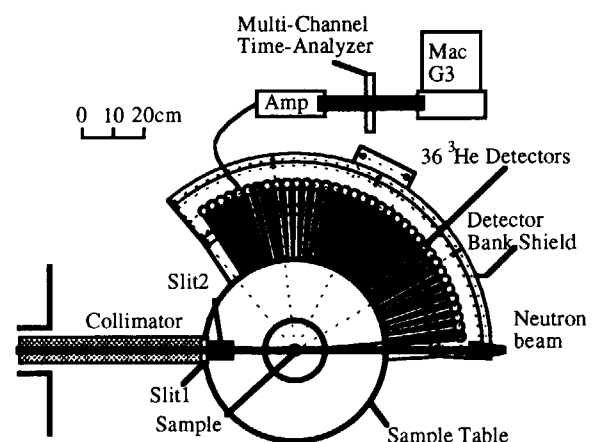

The 36 detectors can cover  $120^\circ$  scattering angle and the range from  $5^\circ$  to  $150^\circ$  is measured by rotating the bank. This angle covers the  $Q$  range between 0.25 and  $40 \text{ \AA}^{-1}$ . The distance between sample and detectors is 550mm and a collimator of  $W16 \text{ mm} \times H40 \text{ mm} \times L230 \text{ mm}$  is attached to every detector. Around the detectors and collimators,  $B_4C$  powder hardened with epoxy resin bond was stuffed for the lower background. A collimator composed with the sheets of  $B_4C$  and Fe was inserted into a beam tube. Incident beam is also collimated before the sample by  $B_4C$  collimator with a hole of 20mm diameter. Beam size is changeable for both vertical and horizontal directions by slits after the collimator. These apparatuses were designed ourselves and most of them were constructed in the factory at KEK to save the cost. A personal computer (Apple, Power Macintosh G3) controls the data acquisition system. The computer also controls the slits, crystal tilts or angle, scattering angle and temperature (2.6 K to 300 K) by GPIB. The  $Q$  resolution was measured by Bragg peak profile of Al single crystal. Since we use thermal neutrons with short flight path ( $L = 6.15 \text{ m}$ ), it is rather worse;  $\Delta Q/Q$  is 2% for high angle region and higher than 5% for low angle region.

### 3. Recent studies on FOX

Recent studies on FOX have revealed that the instrument is ideal for reciprocal space surveying such as diffuse scattering studies or measurements of magnetic satellite peaks. For example, in the study of Pt-Mn spin-glass alloys, unexpected fourfold splitting in magnetic diffuse scattering whose intensity was less than  $10^{-3}$  to those of Bragg peaks was clearly observed. The scattering is due to a strong correlation between magnetic and atomic order [1]. From the observation of satellite peaks in large reciprocal lattice, two-dimensional magnetic ordering in  $TbRu_2Ge_2$  and  $DyRu_2Si_2$  was found in the first place [2]. Application to the observation of phase transition is also on progress now. Taking into account the rather low intensity, low resolution and low cost on FOX, it is concluded that its performance is quite satisfactory.

### 4. Future plans

The future plans on FOX is following,

1. Quantitative data analysis: We need to establish the way to analyze the data more quantitatively.
2. Sample environment: Experiment under high magnetic field or high pressure etc. should be capable.
3. More detectors: One-dimensional detectors to two-dimensional detectors.

### References

- [1] M. Takahashi et al., Proceedings of ASR-2000. To be published in Suppl. J. Phys. Jpn.
- [2] S. Kawano et al., Proceedings of ASR-2000. To be published in Suppl. J. Phys. Jpn.