



ICANS-XV

15th Meeting of the International Collaboration on Advanced Neutron Sources

November 6-9, 2000

Tsukuba, Japan

18.1**Renewal of KENS TMRA**M. Kawai^{1*}, S. Yasui², M. Furusaka¹, T. Ino¹, N. Torikai¹, Y. Kiyanagi²¹ KENS, KEK, Tsukuba-shi, Ibaraki-ken 305-0801, Japan² Hokkaido University, Sapporo-shi, Hokkai-do 060-8628, Japan

*E-mail: masayoshi.kawai@kek.jp

Abstract

The sub-cadmium neutron flux of the cold-neutron moderator of KENS was reduced into about 30% of the nominal design value because the cadmium liner was ragged due to heavy swelling through a 20-years operation. Since it seemed to be very difficult to repair the liner under the high radiation level and possible hazards due to chemical poisoning of beryllium compounds because of not having proper remote-handling equipment, we decided to replace the whole target-moderator-reflector assembly (TMRA). Neutronics designs were made by using the LCS-2.7 code system in order to not only reduce amount of beryllium, but also to improve the neutron characteristics, such as the source intensity and the pulse shape. The new TMRA has a gadolinium-poisoned ambient moderator and composite reflectors of graphite and beryllium. The tantalum target has been replaced with a tantalum-clad tungsten target, which was fabricated by the HIP process. The first neutron pulse from the new TMRA was ejected on November 1, 2000.

1. Introduction

KENS was constructed in 1980 [1] for material science. Its TMRA is the only system which have very high de-coupling energy that enable us to use the resonance analyzer TOF spectrometer. It has been operated at 3 kW with a proton beam of 500 MeV in energy and 6 micro-ampere in beam-current. Proton pulses with 50 ns width bombard the target at 20 Hz. Three kinds of targets were used: a tungsten target from January 1980 to November 1985, depleted uranium one from December 1985 to November 1996 and tantalum one from December 1996 to June 2000. The tungsten target was changed to depleted uranium to increase the neutron intensity by about 50%. The first uranium target had been used for 10 years, but discontinued because Xe-135 was detected in the coolant water reservoir tank. The

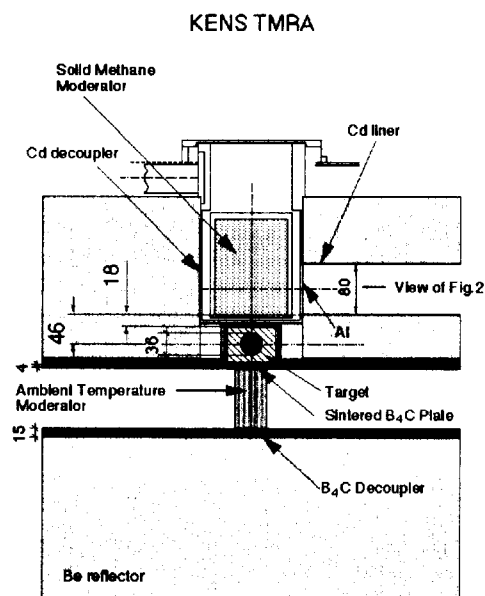

Fig. 1 Configuration of the old TMRA

second and third uranium targets had very short lives of 2 months and only one day, respectively. Therefore a tantalum target was substituted for the uranium one. The thermal neutron source was composed of a target, an ambient moderator with a size of 100mm x 100mm x 50mm, a beryllium reflector with an overall size of 600mm and a thick B₄C decoupler as shown in Fig. 1. Initially, a polyethylene moderator was used, but was replaced with a water one in 1988. The cold-neutron source was also composed of a solid methane moderator of 100mm x 150 mm x 50mm, a beryllium reflector and a cadmium de-coupler. A cadmium lining was also affixed on an aluminum case forming a part of the cold neutron beam line near to the moderator. The nominal cold-neutron flux generated by it was several times lower than that of the ISIS liquid-hydrogen moderator in spite of about one fiftieth of the proton beam intensity of ISIS.

In 1998, an absolute measurement of the neutron fluxes was made at various neutron beam lines by a gold foil activation method and by a fission detector. From its results, the sub-cadmium neutron flux of the cold neutron moderator was found to be about 30% of the nominal design value, while the epi-thermal neutron fluxes were nearly equal to the nominal value. The neutron spectrum of the cold-neutron moderator was also measured by a time-of-flight method using a ²³⁵U fission detector. The measured neutron spectrum was depressed in the energy region below the cadmium cut-off energy of about 0.5 eV from the simple Maxwellian distributions with a 1/E tail. It had been considered that the flux reduction below 0.5 eV seemed to be caused by a part of cadmium-liner came off the aluminum case and shielded the beam line. In order to confirm this, an inspection was made of the cadmium-liner in November and December in 1998. Figure 2 shows the interior of the cadmium-liner after cutting the aluminum window of the liner. It was uneven because of heavy swelling of cadmium, and the color appeared more or less white, but dark yellowish parts were seen

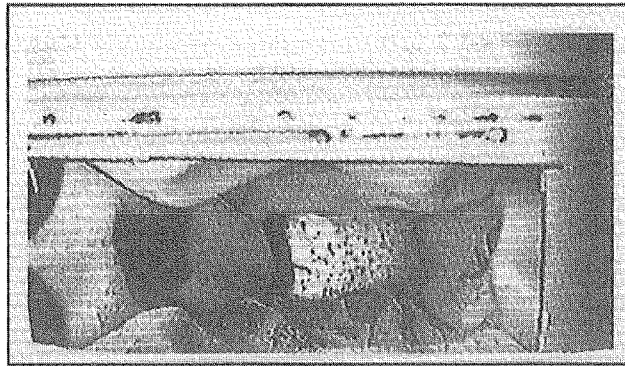

Fig. 2 Interior of the cadmium liner of the cold-neutron source

around the rivets. The swelling must have occurred due to repeated heating and radiation damage. Since

We seriously discussed several methods to repair the liner. Since it seemed to be very difficult to repair the liner under the high radiation level and possible hazards due to chemical poisoning of beryllium compounds because of not having proper remote-handling equipment, we decided to replace the whole TMRA by a new one. The new TMRA was designed by means of neutronic calculations to improve neutronics performance, such as the source intensity, sharpness of thermal neutron pulse while saving on the fabrication cost. The tantalum target was replaced with a tungsten one in order to increase the whole source intensity. We put plates of stainless steel just above the liner to increase the S/N ratio at the neutron instrument. The present paper describes the new TMRA, while emphasizing the neutronics design and the fabrication of the tantalum-clad tungsten target blocks as well as giving a brief description of the components fabrication.

2. Neutronics Design

A neutronics design was made by using the Monte Carlo radiation transport code system LCS-2.7[2] developed at LANL. Proton and higher energy neutron behaviors were calculated with the LAHET code. The neutron behavior below 20 MeV was calculated with the HMCNP code modified from the MCNP/4A code and with the neutron cross sections based on the ENDF/B-V. The absolute neutron spectra at representative positions were scored with the point estimator tallies located at positions of 10 m distance from the thermal and the cold moderators with the 40,000 source protons of 500-MeV energy. Neutron time spectra of the pulse were scored with large spherical estimators of 10 cm diameter located beside the moderators with the 2,000,000 protons.

In the neutronics calculations, the arrangement of a composite reflector of graphite and beryllium was initially determined so as to recover the cold-neutron source intensity within 90% of the nominal value, using the same combination of tantalum target and moderators as those of the original i.e., the old KENS, which had a reflector made almost of beryllium. The

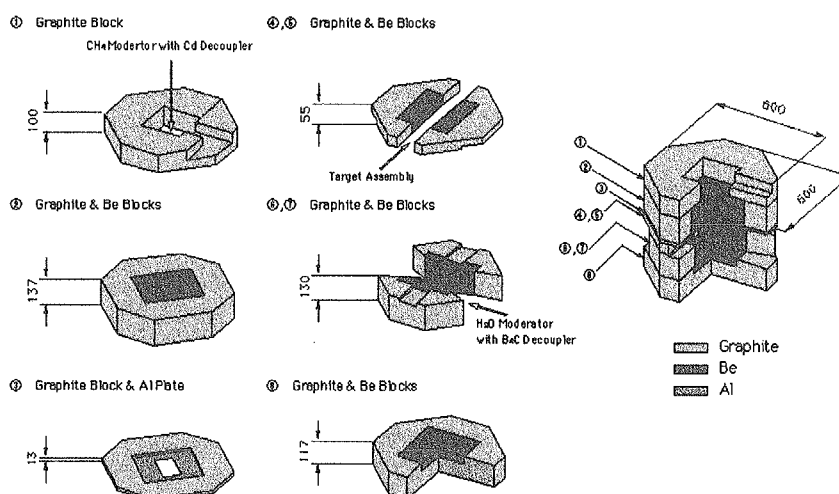

Fig. 3 Structure of the reflector composed of graphite and beryllium

desired cold-neutron source intensity was obtained by optimizing the location of a small amount of beryllium reflector around the moderators and the target surrounded by the graphite reflector. Figure 3 shows the structure of the reflector finally determined. The size of the reflector is the same as that of the old one. However, the total amount of beryllium was decreased from about 200 kg to only 34.8 kg.

The composite reflector of graphite and beryllium gave such high thermal neutron flux that a 0.3 mm thick gadolinium poison was used in the center plane of the ambient moderator. The gadolinium poison made a thermal neutron pulse sharper in the energy region below 100 meV. Figure 4 compares the neutron pulse spectra at 45.7 meV. It can be seen that the new KENS gives a faster decay of the pulse and a smaller FWHM than the old KENS. The decay constant of a tail of the neutron pulse, β , is about twice of that of the old value in the energy

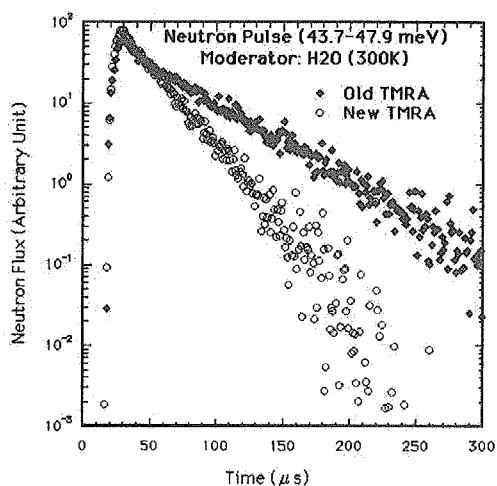

Fig. 4 Comparison of the pulse shape of the thermal neutrons at 45.7 meV

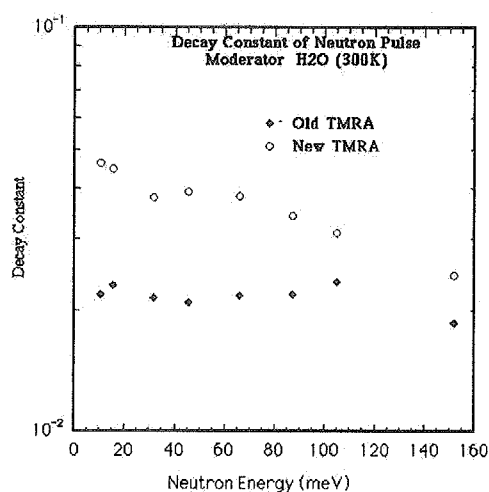

Fig. 5 Comparison of the decay constant of the thermal-neutron pulse as a function of the neutron energy

region up to 70 meV, as shown in Fig. 5. The FWHM is 30% smaller.

As for a cold-neutron source de-coupler, we employed 0.5 mm cadmium as in the case of the old TMRA. A B₄C de-coupler was employed for thermal neutrons. Its de-coupling energy was determined by investigating the sensitivity of the neutron pulse shape over a wide energy range from 10 meV region to several tens eV. Especially, the de-coupling energy at such high energy is important for a special neutron instrument eV spectrometer based on a resonance-analyzer TOF method. Figure 6 shows the typical result for neutron pulse in the energy range between 4.37 eV and 4.79 eV. A tail part at a longer time region decreases with an increase of the de-coupling energy, but the peak intensity is not so sensitive to the de-coupling energy. Finally, the de-coupling energy was determined to be 100 eV for the interface plane between the ambient moderator and the target, and 50 eV for the other parts. These values are fairly smaller than those of the old TMRA: 488 eV of the sintered B₄C beneath the target and 95 eV of 11 mm thick natural B₄C powder at the other sides of the de-coupler.

The overall source intensity was increased by about 20%, by replacing the tantalum target with a tungsten one. Figure 7(a) shows the calculated cold-neutron spectrum from the

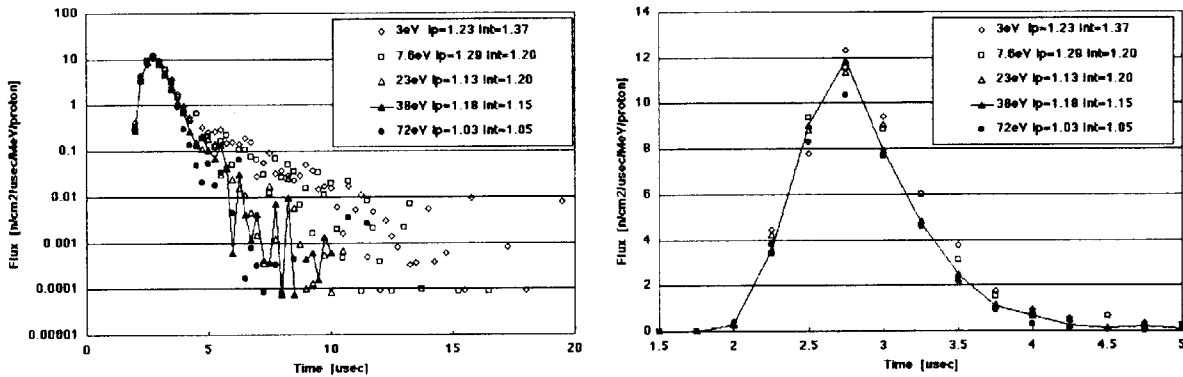
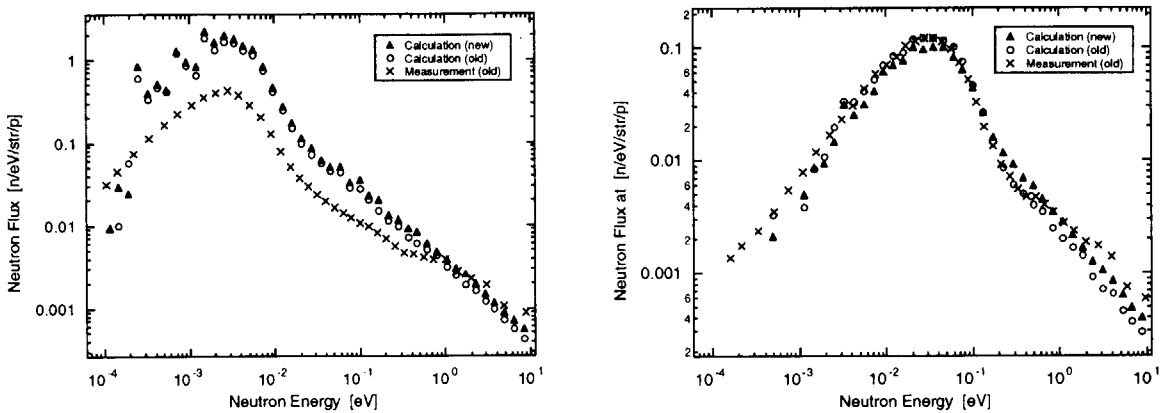

Fig. 6 Variation of Pulse Shape at 4.6 eV with the De-coupling Energy



(a) Cold Neutron

(b) Thermal Neutron

Fig. 7 Comparison of Neutron Spectrum

methane moderator at 20 °K for the new TMRA having a tungsten target compared with the calculated and measured ones for the old TMRA of the tantalum target. It is found that the measured data are about a factor of 3 smaller than the calculated values, and that the new data are slightly higher than the old one. Calculated thermal neutron spectrum from the ambient moderator of water at 300 °K of the old KENS is in good agreement with the new calculated values over the energy range near to the Maxwellian peak. The new spectrum that corresponds to a time integrated intensity is larger than the old one at higher energies above 200 meV, but slightly lower than the old one in the lower energy region below 100 meV because of a narrower pulse shape due to gadolinium poisoning, although the peak value of the time spectrum is higher, as shown in Fig. 4.

The influence of the fast neutron background directly coming from the target can be reduced by shielding the direct component by a geometrical consideration about the target and the instruments, which are located at opposite sides of the neutron beam line. Figure 8 shows the configuration of the TMRA and the beam line shield for the reflectrometer ARISA. An additional shield of 20 mm thick stainless steel was set on the edge parts of B₄C de-coupler to compensate the lack of shield thickness.

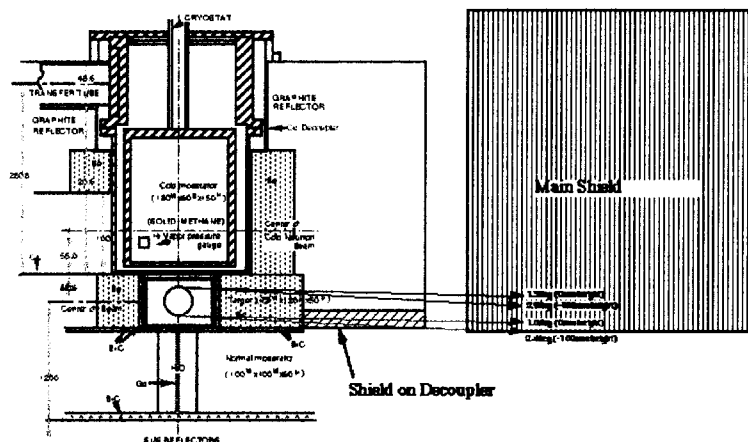

Fig. 8 Configuration of the TMRA and the Neutron Shields. Arrows show neutron flows from the target into the entrance of the reflectrometer ARISA.

3. Fabrication of a Tantalum Clad Tungsten Target Block

Although tungsten has a better neutronics performance, it is well known to be corrosive in water, especially under circumstances of radiation. Tantalum has good compatibility with water and, even more, has an advantage of neutron generation efficiency compared to other structural materials, such as stainless steel, zircalloy and niobium. Therefore, we decided to clad the tungsten block with tantalum plates by the HIP (hot isostatic press) process. The details concerning the fabrication of the target block is described in Reference 3. We would

like to summarize the method below.

The target assembly is composed of four blocks, as shown in Fig. 9. The most front block has a hole for inserting a thermocouple. The blocks are of 29.18mm X 56.16mm x 76.89mm size and is covered with 0.6 mm thick tantalum clad. Each block is separated by spacers to make gaps of 2mm between the blocks. The coolant water flows through the gaps between blocks at a total flow rate of 60 liters per minute. The tungsten block was made by forming from a rolled tungsten block of 19.2 g/cm³ density and 99.99% purity by an electro-discharge machinery (EDM or spark erosion) technique. A hole for a thermocouple was made by the plunge EDM technique. The tantalum clad is composed of a trunk and two caps. The trunk was made of a sheet of 0.8 mm thick tantalum of 99.987% purity by using a model that was formed by fitting to the actual tungsten block. The edge of the sheet was bonded by TIG welding. A cap with 2.2 mm depth was made by EDM and end-mil work against a 3 mm thick sheet. The tungsten block was assembled into the trunk and covered up by the caps. Each edge of the trunk and cap were tentatively welded at four spots joining the trunk with the cap. Then, the clad composed of trunk and caps was perfectly sealed by welding the both edges by about 1 mm depth by the electron-beam-welding method under the vacuum condition of 0.4 Pa. A color check was made to confirm the welding result. In the case of a block having a hole for a thermocouple, a tantalum sheath for the hole was made of slim pipe with 1.6 mm inner diameter and 0.8 mm thickness by filling the bottom

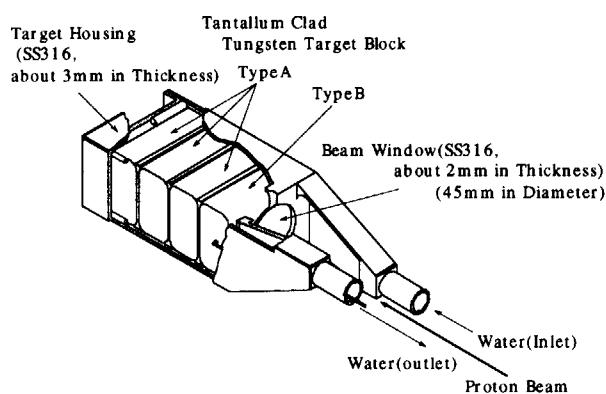

Fig. 9 KENS Target Housing and Target Blocks

edge with a small pellet. The pipe and the pellet were bonded by TIG-welding.

The HIP procedure was made to bond the tantalum clad with the tungsten block. HIP condition was determined by testing it with small samples. The HIP condition is very important to bond both tantalum and tungsten, which are well known as refractory materials for high-temperature usage. At ISIS, the extreme conditions of 2,000°C and 20,000 kgf/cm² were applied[4]. In the present work, the optimum HIP condition, which was considered to be moderate, was determined by testing with small samples. We found that there were problems, such as gaseous interstitial impurity elements in argon gas severely attack tantalum clad under

high pressure and high temperature. The combination of high- purity argon gas and getter materials was very effective to resolve the problems. After the HIP procedure, the protuberances were cut down and the surface of the block was polished to obtain the designed thickness and roughness.

The processed block was examined by the supersonic diagnostic procedure to check the bonding between Ta/W and Ta/Ta. The HIP process gave good results to the blocks which have no hole for a thermocouple hole. However, the supersonic diagnostic for one of the blocks with a hole suggested that there were some defects around the hole. Additionally, an imperfect bond was found after polishing the surface of the block. Then, we repeated the process carefully. A second block with a hole gave a better ultrasonic image. Figure 10 shows the supersonic echo from a depth of about 14 mm in a block with a hole for a thermocouple. It can be seen in Fig. 10(a) that there are some kinds of defects around the hole. It is important to clarify the kinds of defects and the reasons for 'we failed to HIP!'. Figure 10(b) shows that the echo from the secondary made block with a hole. It displays a beautiful pattern of the hole. Finally, we adopted the second block. Figure 11 shows the four blocks presently fabricated. These blocks have been installed in the new TMRA.

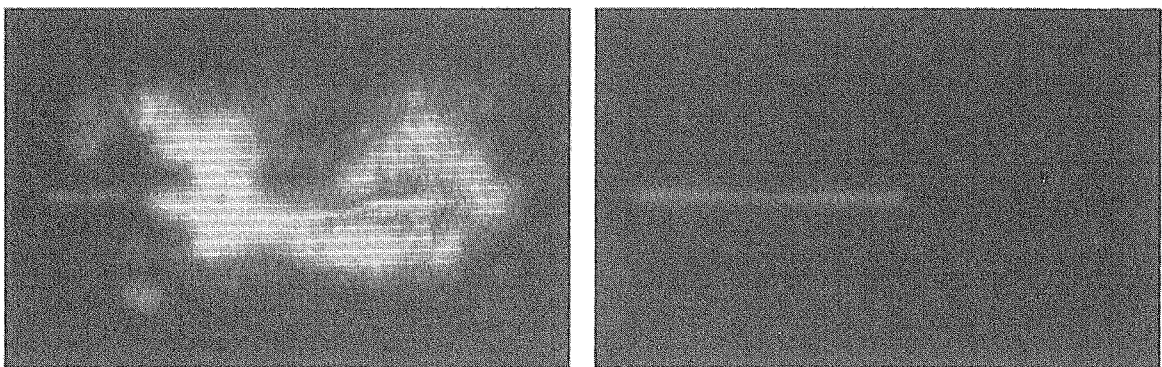

(a) First Made Block: Defected

(b) Second Made Block

Fig. 10 Supersonic Echo from the Depth of About 14 mm in Block with a Hole for a Thermocouple 43.5 mm in Length.

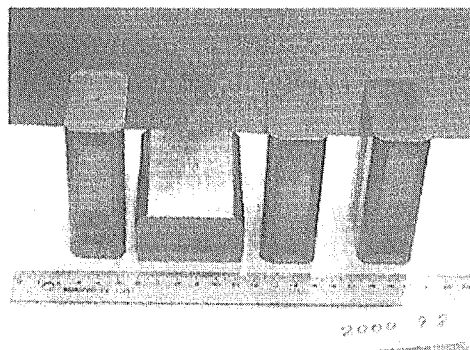

Fig. 11 Target Blocks after Polishing with 29.18mm X 56.16mm x 76.89mm Size

Further investigations were made to clarify the reasons for the failure of the HIP process for the block with a hole. At first, the defected block was cut at a position of about 2cm distance from the cap with a hole where the queer pattern was found in the super sonic echo. We clearly observed that the bonding was imperfect at both interfaces between the tantalum means that high pressure was not loaded to the tantalum cover during the HIP process. Next, we tried to find cracks in the tantalum sheath with a soapy water babbling method by pouring air into the sheath. It is difficult to find any bubble formation in the gap between the sheath and the tungsten block. This fact means that there is no apparent crack which makes a leaking path of air. Third, we observed the cut section of the block with an optical microscope. Figure 12 gives the microscopic observation result. It can be seen from the figure that there is a slim and long crack penetrating through the tantalum pipe outward, although the crack is disconnected in places. We also investigated small cracks by neutron radiography at JRR-3M and did not find any defects with a spatial resolution of 80 μ m, as shown in Fig. 13.

Finally, it can be concluded that the crack must be a trace of a rupture which was probably created when a high isostatic pressure of 2,000 kgf/cm² was loaded before the tantalum pipe became hot and ductile enough, since the pipe was surrounded by the tungsten block and the hardest heated by the furnace. Accordingly, in order to avoid any defect of the HIP in the case of the block with a hole for a thermocouple, at least two methods can be proposed. One is to delay start-up of the compressor until the tantalum pipe is sufficiently heated enough to obtain ductility. Another is to make the HIP process against a block with no hole at the first step, to imbed thermocouple with a tantalum sheath into a hole made by the plunge EMD at the second step and to weld the tantalum sheath to the tantalum cover.

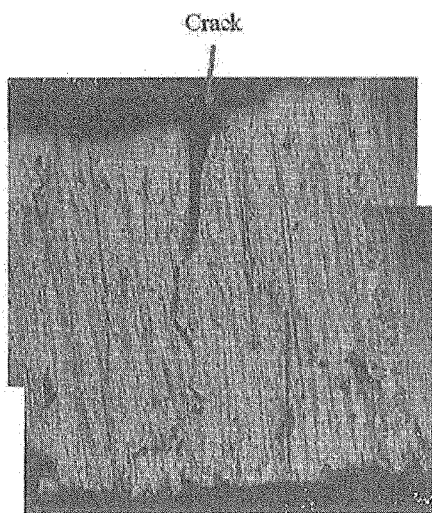

Fig. 12 Optical Microscope Observation of a Cut Section of the Tantalum Sheath with 0.8 mm Thickness for the Defected Block.

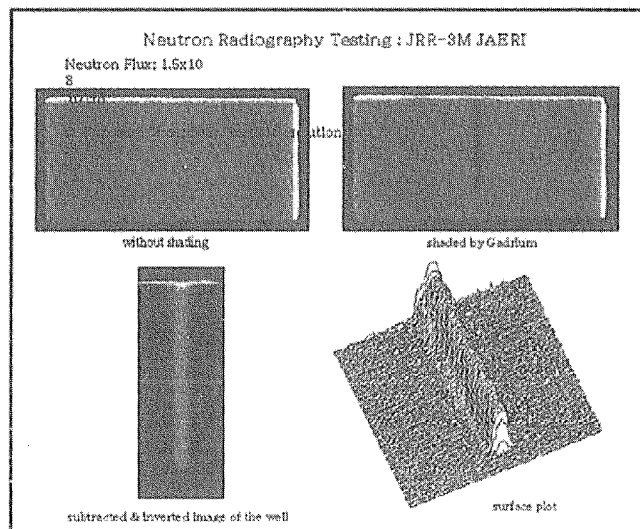

Fig. 13 Neutron Radiography Image of the Intermediate Part of the Defected Block.

4. Other Components and Renewal Work

We have made some technical contrivance for the components of the new TMRA and renewal work. A graphite reflector was treated with a CVD method to avoid carbon dust. It will increase the radiation safety on the TMRA repair in the future. The cadmium liner of the de-coupler for the cold moderator was put on the side against the moderator. Its position will be effective to guard against an attack of nitrogen oxide under radiation. A thermal de-coupler was made by combining sintered B₄C plates, which were polished into the desired thickness.

Before the actual renewal work, a simulation of the procedure was made by using the mockup apparatus of the TMRA and its trolley, in order to reduce the radiation exposure on the work under the high radiation level of the 50 mSv/hr in maximum near to the old TMRA. Alignment of the TMRA was made on the mockup trolley with a help of laser-beam equipment which automatically indicates the horizontal and vertical lines. Laser pointers were very useful to set up the old simple tools to lift the TMRA components and shield plugs on to the trolley which had high radio-activities and was drawn back in the deep shield pit.

5. Summary

Renewal of the KENS TMRA has been completed. Its neutronic design was made with the Monte Carlo code system LCS-2.7. The calculation showed good agreement of the thermal-neutron spectrum with the measured data. Cold neutrons were sufficiently recovered by using the composite reflector of graphite and a small amount of beryllium, and the tungsten target. The performance of thermal neutrons was prominently improved by using gadolinium poisoning, which gave a higher peak intensity and shorter tail pulse. Tantalum-clad tungsten target was successfully fabricated by the HIP process using high-purity argon gas and impurity-gas getter materials of zirconium foils and tantalum slabs. The stainless-steel plates were equipped on the de-coupler of the ambient moderator so as to increase the beam line shield against the fast neutrons from the target.

Actual replacement of the TMRA has been made during August 31 to September 21. The first neutron pulse from the new TMRA was ejected at 16:37 on November 1, 2000. The neutron measurements were made[5,6] for absolute fluxes, energy and time spectra and time.

Acknowledgements:

The authors are very grateful to Dr. Kenji Kikuchi of JAERI, Professors Hiroaki Kurishita and Jing-Feng Li of Tohoku University and Nobuyuki Takenaka of Kobe University for their helpful cooperation about the HIP process and the inspection of the tantalum-clad tungsten blocks.

References:

- [1] Y. Ishikawa, Present Status the KENS Facility, Proc. of the 4th Meet. of the International Collaboration on Advanced Neutron Sources (ICANS-IV), KEK, Tsukuba, October 20 - 24 , 1980, p.181, KEK (March 1981).
- [2] R.E. Prael, et al., User Guide to LCS: The LAHET Code System, LA-UR-89-3014 (1989).
- [3] M. Kawai, et al., Fabrication of Tantalum-Clad Tungsten Target for KENS, presented at 4th International Workshop on Spallation Material Technology, Schruns, Austria, October 8 - 13, 2000
- [4] T. Broome, ISIS Target and Moderator Materials, Proc. of 2nd Int. Workshop on Spallation Materials Technology, Ancona, Italy, September 19 - 22, 1997, p. 55 , jul-3450.
- [5] T. Ino, et al., Measurements of Neutronic Characteristics of the KENS Target-Moderator-Reflector Assembly, presented at ICANS-XV, Tukuba, November, 6 - 9, 2000.
- [6] S. Itoh, et al., Recent Progress in the Chopper Specrometer, INC., presented at ICANS-XV, Tukuba, November, 6 - 9, 2000.