

3.2.20

The ESS target station hot cell facility and associated logistics for *ICANS XXI*

Magnus Göhran¹, Lennart Åström, Paul Erterius

European Spallation Source ESS AB, ESS, Lund, P.O. Box 176, Sweden.

E-mail: Magnus.gohran@ess.se

Abstract. The European Spallation Source (ESS), Lund, Sweden will be a 5MW long pulsed neutron research facility with planned commissioning in 2019. Connected to the target station building, a hot cell facility will deal with the large, heavy and complex radioactive components as they reach their lifetime limit after service in the neutron research facility. The hot cell will be unique in its design for this specific reason. A special precondition for ESS, being a green field facility, is that there is neither a heritage nor any logistical constraints, which is often the case for existing facilities. The ESS will be operational for around 40 years once commissioned and the hot cell facility will be operative during the complete operational phase of ESS as well as being an important facility during the decommissioning phase of the ESS. This requires the design to have a very high degree of flexibility in order to adapt to changes of target station component designs as well as changes of the functional requirements for the hot cells themselves.

1. Introduction

The design of the Active Cells comprising the hot cell facility of the European Spallation Source ESS AB is in a crucial phase of preliminary design with a planned preliminary design review in mid December 2014. The layout and logistics of the Active Cells is intended to be able to treat and process spent radioactive components mainly derived from the ESS target station operation. The Active Cells facility is scheduled to be operational during the lifetime of the ESS (including decommissioning) and consideration of a flexible and versatile design is therefore crucial in order to fulfil the scheduled tasks, also taking into account that most spent components coming from the ESS operation will most likely be experiencing design updates during the ESS operation. Furthermore, the operation of the Active Cells should have little or no impact on the neutron scattering reliability and availability.

The main purpose of the treatment of the radioactive spent components is to meet the Waste Acceptance Criteria (WAC) as specified by transport, interim storage and/or final repository. As of today, the WAC is not yet known and that will have an influence on the layout and design of the Active Cells as well as on its systems and equipment.

This paper will discuss the current plans for the design of the ESS Active Cells facility and how this design take into account the uncertainties of the requirements. This also includes some degree of novelty to the design and layout both in order to be able to meet future or changed requirements once operational but also to try to address other issues when dealing with hot cells and remote handling. The later is also important due to that the ESS is a green field facility and do not rely on any heritage

¹ To whom any correspondence should be addressed.

from previous operation, this imply that the green field facility design and construction could be both a risk and an opportunity for the manufacturing of the Active Cells facility.

2. Currently planned Active Cells layout and design

In order to fulfil the requirements on receiving the spent radioactive components from the target operation as well as to treat these components to fulfil the WAC for shipping and receiving storage facility, the layout and structure of the Active Cells has been developed into 5 main areas. The *process cell* where the spent components are received, treated and loaded into waste baskets, the *maintenance cell* that functions as the logistical hub for transport of waste container as well as a location for hands on maintenance on the Active Cells equipment, the *storage pits* where waste baskets can be stored prior to offsite shipment, the *transfer area* where offsite shipment containers are loaded with waste baskets prior to shipping and the *technical galleries* from where all in-cell operations are performed and the Human Machine Interface (HMI) is located. The currently planned main features of the layout are shown in Figure 1 and the layout is further explained beneath. The inside dimensions of the hot side of the cells are roughly (30x12x15) meters (LxWxH).

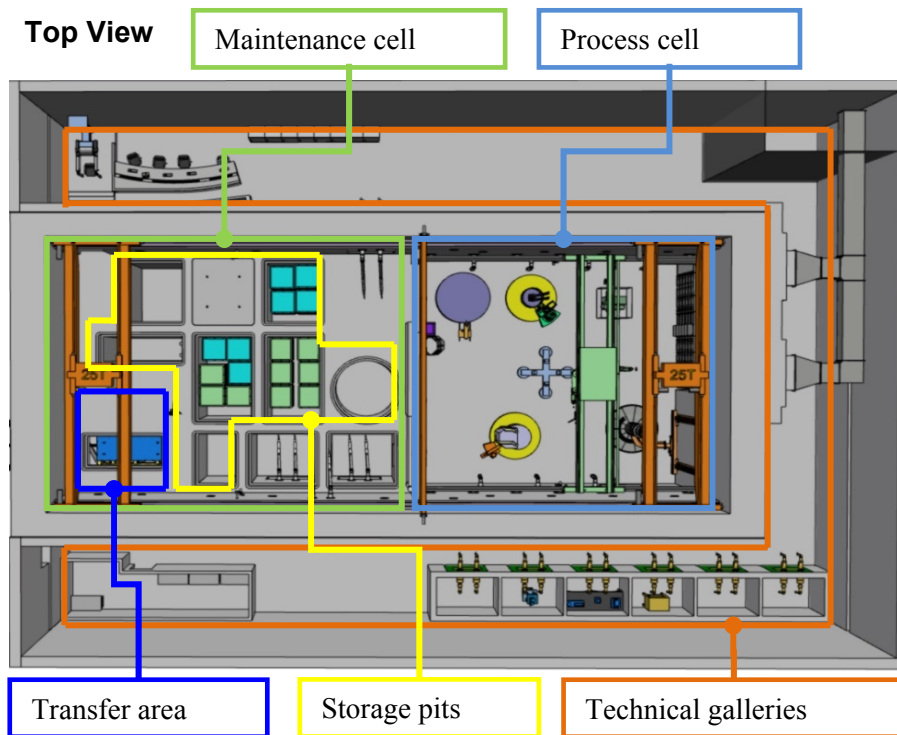

Figure 1. The Active Cells layout.

2.1. Process Cell

This part of the Active Cells has an interface to the high bay above where the radioactive spent components are loaded through a floor valve. The components are loaded to a centre position and then, depending on what component it is, moved to a certain pre-dedicated position for process and treatment. The treatment could be cutting and dismantling in order to separate materials and activation to ease and minimize risk of not fulfilling WAC for shipment and receiving facility. The waste is loaded into dedicated wastebaskets. The other structural interface is through an intra bay door that separates the process cell and the maintenance cell; here components, equipment and wastebaskets can be transported back and forth between the cells.

2.2. Maintenance Cell

The maintenance cell is dedicated for logistics of the wastebaskets transported from the process cell, either the baskets are loaded into a storage pit or through the transfer area into a shipment container. In the maintenance cell, personnel have access through an airlock to do maintenance on process and maintenance cell equipment and tools. The human access will be subjected to some preconditions as for example that the access will be done in pressure suits, the storage pit lids are in place and the intra bay door is closed.

2.3. Storage Pits

The storage pits are situated beneath the maintenance cell floor connected to the maintenance cell via hatches. The purpose of the storage pits is to provide an interim storage of waste until shipment is possible. Depending on the filling degrees, maximum weights, activity, etcetera of the wastebaskets, the storage capacity volume will hold at least 15 years of target station radioactive waste.

2.4. Transfer Area

The physical connection to offsite shipment is done through the transfer area with the possibility to transport shipment casks inside a confined area for direct top loading of wastebaskets from the storage pits (through the maintenance cell). The transfer area is designed as an airlock and the design should allow different sizes of shipment containers to be loaded.

2.5. Technical Galleries

All regular operations within the cells are performed from the technical galleries where a control board is located as well as the through wall operating equipment such as the Master Slave Manipulators (MSM). The technical galleries also house the possibility for locating smaller Post Irradiation Examination (PIE) cells.

3. The Active Cells novel design concept

For the Active Cells to be able to meet the expected performance and lifetime with many expected updates in target components as well as changes in the WAC and updates in operations in general, the design of the cells has a high focus on versatility and operational flexibility. One of the most constraining parts of a classical hot cell operation or remote handling in general is the location and performance of the HMI. For a hot cell, classically the operator would have been placed in the technical galleries in front of a shielded glass window with two manipulator arms to work with inside the cell. The drawbacks of this setup are limited view angles, high demands on in-cell lights, operator fatigue and low utilization of the manipulator arms. The ESS Active Cells is addressing these issues in a concept called the *novel design* and the concepts are further described below.

3.1. The Human Machine Interface

If the in-cell operation as well as the through wall operations is done from a central control table, the operator HMI is moved from the face of the wall to the control table. A sketch of how this interface could look like can be seen in Figure 2. This implies two things, first that the MSM's are driven by motors instead of operator physical force and the second thing is that the operation is performed via a video feed instead of a direct view of the operation.

The motorized MSM depicted in Figure 3 is a commercial product with a tested performance with a very good feedback from operators on technical, operational and cost perspectives [1]. Since the physical extension with the motorized arm is not bound by the reachability of the operator, as a synergy, the motorized arm now has a possibility to also reach upwards. This is of course beneficial considering the size of the Active Cells.

Pursuing the placement of the operator in front of a control board, the operation inside the cells will now be done with joysticks and controls that should utilize a haptic behaviour to get the most realistic behaviour of the controls as possible. Furthermore the operation is done via cameras.

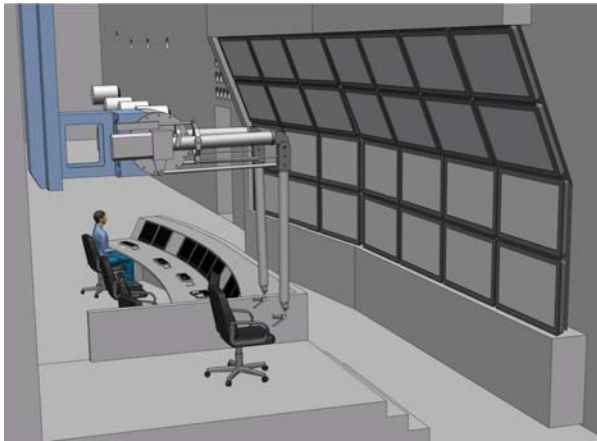

Figure 2. Sketch of a control board for running and controlling the in-cell operations.

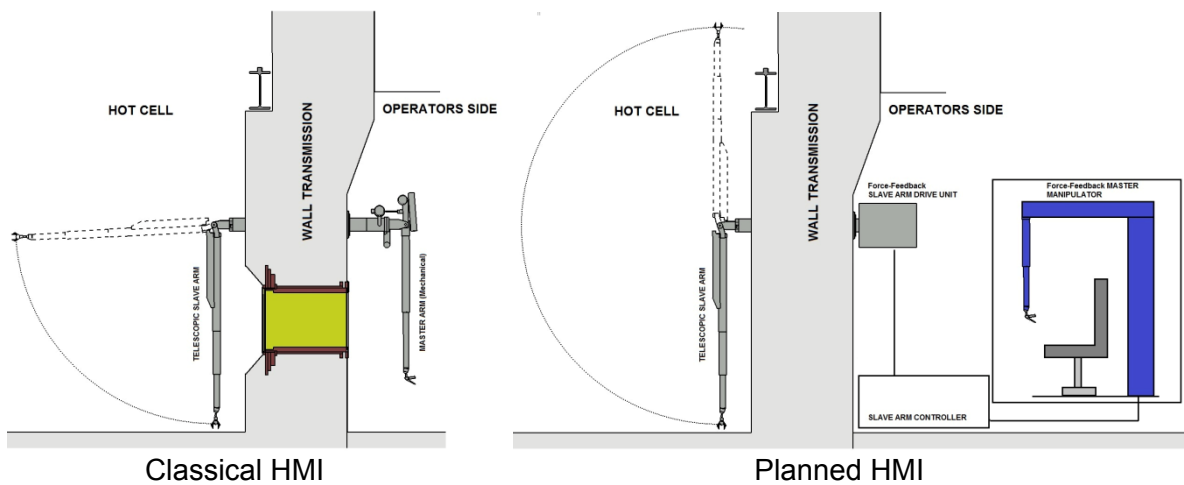

Figure 3. Difference between the manual and motorized master-slave manipulators.

3.2. Visualization

Expanding the thought on placing the operator in front of a camera feed of the cell interiors with a joystick controlling the equipment that incorporates a haptic feedback, the need for the shielding windows are no longer obvious. However there might be occasions where a window is needed and thus the project plans on incorporating at least the embedded frames for some window in the process cell and some in the maintenance cell. Excluding the windows from the day-to-day operation, the requirements on the in-cell lights is reduced significantly and there might be opportunities to use standard LED street lights for the operation.

The camera system will be the main visualization system for observing the operations and this now puts some stringent requirements on the camera system and how this system will be used. The novel concept will utilize a set of through wall plug cameras and in-cell cameras mounted on equipment and other structures. The video feed will be processed through a computer and integrated with CAD models in order for the operator to use a virtual camera position with a convenient viewing position. The viewing system is thus utilizing augmented reality [2] as a tool for the operator to get a clear view of the process inside the cells.

3.3. Master Slave Manipulator layout

The classical setup of a hot cell workstation is designed with two MSM's in front of a shielding window. By this setup, the working volume of the MSM's are very much overlapping which of course

could be both beneficial and inadequate depending on the operation that is performed. By shifting the HMI from the walls to the control board, there are no longer any need for placing the MSM's in a suitable position for the operator (in terms of height and distance between them). Working volume and overlaps, penetration heights etcetera could now be optimized for the planned work for each arm. By including a grid of plugged penetrations, the arms could then be moved to a suitable position to accommodate the changed needs including a high degree of flexibility of the future operations of the Active Cells. The difference between the working volumes of a normal hot cell set up of manipulator arms and the suggested motorized arms are displayed in Figure 4.

The penetrations used by the MSM's should be developed so that all equipment that will be routed through the walls of the cells has the same size. If so, the operation could chose if there should be a camera or a MSM or any other utility routed in a specific penetration position.

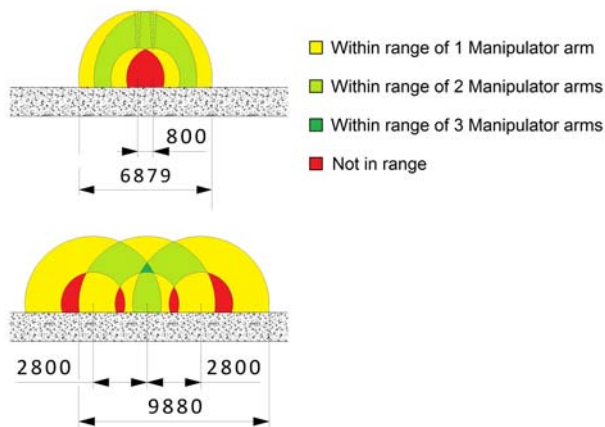

Figure 4. Top picture are describing the working volumes of a classical MSM set up and the bottom picture is a suggestion of spreading the arms out along the length of the wall, optimizing the working volume.

3.4. Mock-up testing of operation

By implementing the systems, functions and designs discussed in the sub-chapters above, placing the operator in front of a control board utilizing haptic controls and augmented reality, the mock-up testing of most operations could be performed in the same environment as the live operation. The operator will use the same controls but do the operation in a mirrored virtual reality environment instead of the actual in-cell reality.

4. Target Wheel dismantling

The wheel function and design is described in [3]. The size, weight and difference in activity of the different materials require the wheel to be dismantled prior to offsite shipment. The aim of the dismantling is to separate tungsten from stainless steel and to separate low active parts like the top of the shaft from the highly activated parts like the beam entrance window. The currently chosen method for dismantling is dry cutting utilizing a high-speed circular saw mounted on the wall. The wheel assembly is positioned on a rotating table and the saw has another 4 degrees of freedom making the cutting as flexible as possible. The saw is shown in Figure 5 where the first top part of the shaft is cut of and removed by the in-cell crane. The size and foremost the height of the target wheel assembly has a large impact on the total size of the hot parts of the Active Cells.

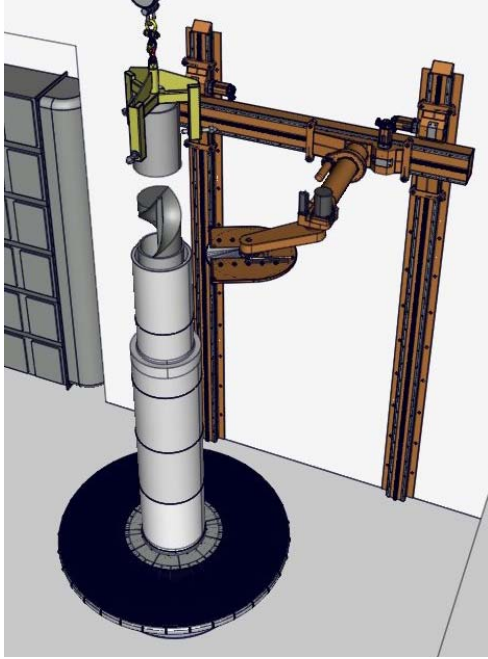

Figure 5. Detail of the target wheel disassembly. The wall mounted saw in orange and the wheel assembly in grey. The first top piece of the shaft is cut and lifted by the in-cell crane.

5. Waste logistics

Since the WAC is not yet determined and agreed with the stakeholders, the design of the Active Cells as well as the planning of the logistics for the waste should be flexible enough to accommodate a variety of offsite shipment containers. The waste should also be separated and sorted in a way so that the risk for having to re-pack and re-distribute the waste once the WAC is known should be minimized. By introducing the philosophies of flexibility to the design, the logistics will also be adoptable to future changes in the chain of transportation.

Once the WAC is known a detailed BAT (Best Available Technique) analysis will be performed that will set the parameters for the shipment. The offsite shipment itself will be under ADR-S [4] regulations.

The reference system used as the design basis is the currently used and adopted system used by some of the Swedish NPP's. An approximate number of 200 containers within this system are deployed as of today for radioactive waste storage. Depending on activity, the containers can be built with 50, 100, 150 or 200 mm wall thickness (steel).

The loading of the interim wastebaskets into the shipment container is done in the transfer area, Figure 6. This area has a connection to the transport hall where truck access is possible. The interim wastebaskets, Figure 7, are filled in the process cell and used for the interim storage in the storage pits. These baskets go through decontamination on the outer surfaces in order to avoid contamination of the inside of the shipment containers.

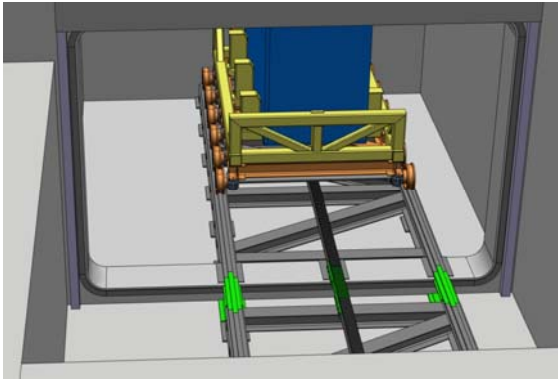

Figure 6. Waste shipment container in blue transported on rails from the transfer area to the transport hall for truck loading.



Figure 7. Detail of the waste shipment container (blue), one side omitted. The yellow wastebaskets are used as interim storage baskets that are eventually loaded inside the shipment container.

6. Conclusions

A lot of effort is currently focused at concluding on the layout and geometry of the Active Cells structural parts. Since some of the functional requirements are still unknown, the design effort is focused on including flexibility and versatility to an as large extent as possible. This is one of the reasons to why the “novel design concept” is presented as part of the solution for the design since this concept will make it possible to adopt the cells to future known and unknown modes of processes and operations. The flexibility and versatility is also adopted for the shipment of waste where the interfaces are developed in such a fashion that they can accommodate a large range of shipment containers.

7. References

- [1] P. Garrec *et al.*, “Evaluation Tests of the Telerobotic System MT200-TAO in Areava- NC/NL Hague Hot Cells”, 2nd Joint Emergency Preparedness and Response & Robotics and Remote Systems Topical Meeting, 2008, Albuquerque
- [2] http://en.wikipedia.org/wiki/Augmented_reality
- [3] R. Linander, U. Odén, “Status update on the ESS Target systems development”, ICANSXXI, 2014, Mito, Japan
- [4] ADR-S: European Agreement concerning the International Carriage of Dangerous Goods by Road (Swedish version). MSBFS 2011:1